

MiTek[®]

HOMEBUILDING SOLUTIONS

ROOF TRUSS INSTALLATION MANUAL

2022 / ISSUE 1

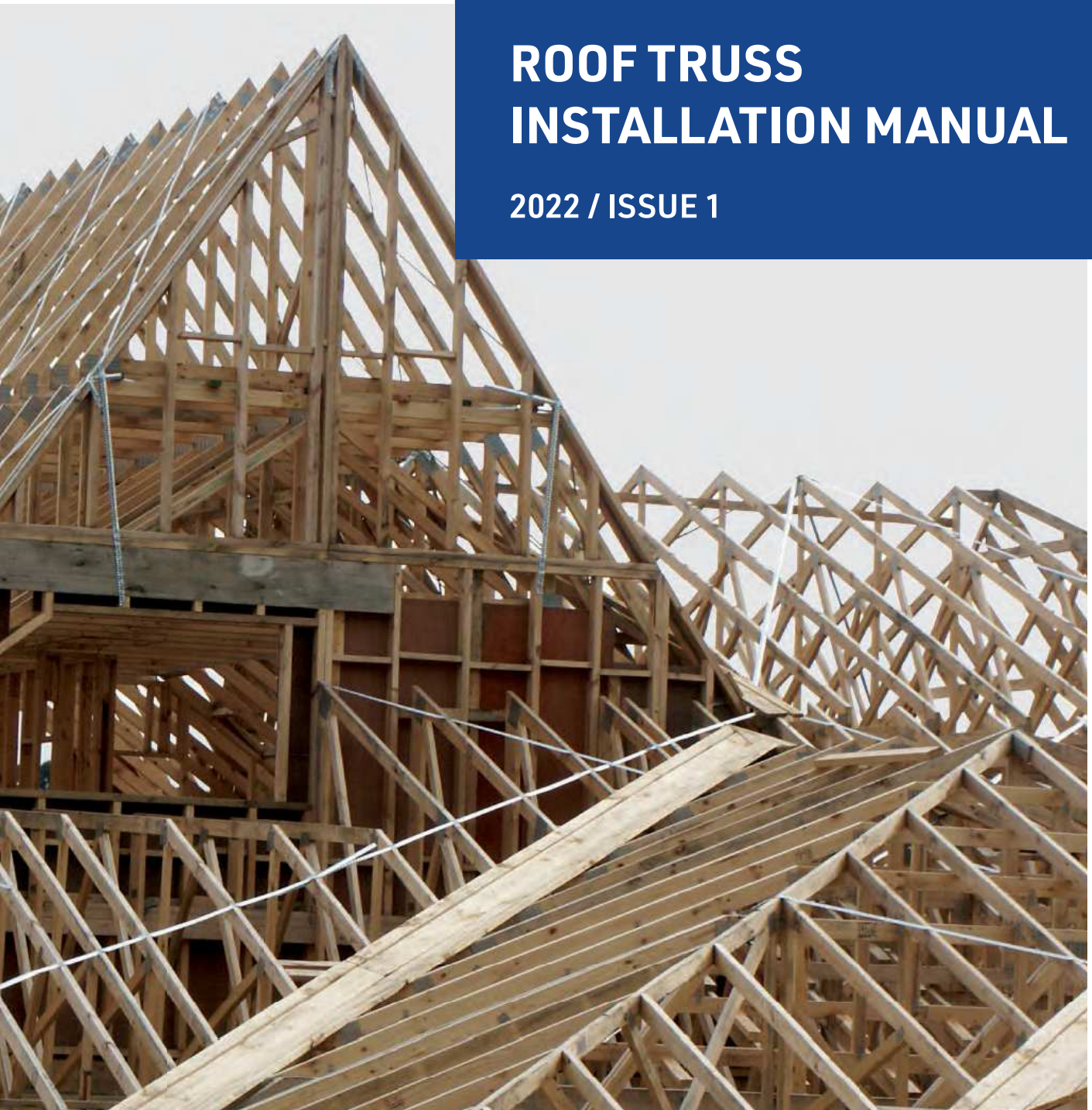

TABLE OF CONTENTS

Fixing & Bracing Guidelines For Timber Roof Trusses

General	2
Design	3
Transport	3
Job Storage	3
Roof Layout	4
Erection and Fixing	4
Girder and Dutch Hip Girder Trusses	7
Saddle Truss Fixing	12
Roofing Battens	13
Permanent Bracing	14
Web Ties and Stiffeners	18
Girder Brackets	22
Guard Rail Systems	27
MiTek 20/20 User Guide	29
Truss Installation Checklist	32
Product Certification	32

ILLUSTRATIONS

All technical illustrations in this Guide have been converted to pdf, AutoCAD 2000 dwg & dxf file formats. They are also compatible for use with MiTek SAPPHIRE™ - making them the ideal, easy reference for installation instructions and data. To access these illustrations, please visit our website.

GENERAL

The roof trusses you are about to install have been manufactured to engineering standards. To ensure that the trusses perform as designed it is essential that they be handled, erected and braced correctly. The installation of prefabricated timber trusses is covered by the Australian Standard AS 4440 "Installation of NailPlated Timber Trusses". The following information is an abbreviated set of instructions designed to assist with on site work and is not intended to replace the need to reference AS 4440. The following recommendations apply to roof trusses on standard domestic buildings where truss design details are obtained from MiTek engineering programs. Details for commercial, industrial and non standard domestic buildings, are to be provided by an Engineer responsible for the overall building design.

DESIGN

1. Trusses are designed for normal roof, ceiling and wind loads to suit specific jobs and conditions. Additional loading such as Solar Units, Hot Water Tanks, Air Conditioning, etc. require special consideration. Advice should be sought from the truss fabricator prior to commencing construction.
2. Wall frames and beams supporting trusses must be designed for the correct roof loads. Refer AS 1684 "Residential Timber-Framed Construction" for details.
3. Wind load is an important factor in the design and performance of roof trusses. Ensure that you have correctly advised the truss fabricator with regard to wind load requirements and that adequate provision has been made to fix trusses to the support structure to withstand wind uplift forces.
4. Trusses are generally designed to be supported on the outer wall with inner walls being non load bearing. Where it is necessary to use internal walls for load bearing, these will be clearly shown on layouts. Note that the supporting structure is stable in its own right.
5. Before ordering trusses, ensure that your particular requirements have been provided for and that all relevant information has been supplied to the truss manufacturer. If non standard trusses are being used, ensure that erection and bracing details are known before erection commences.
6. For environments where the atmosphere may be conducive to corrosion, such as some types of industrial and agricultural buildings, or buildings near the ocean and subject to salt spray, consideration should be given to the use of G8S stainless steel connector plates.

Important Note

1. It is the Builder's responsibility to ensure that all relevant information required for design is provided to the fabricator at time of ordering trusses, including spans, pitches, profiles, quantities and loadings. Final confirmation of details by the fabricator with the builder is recommended prior to manufacture.
2. Trusses are designed to be part of a structural system, which includes battens/purlins, bracing, binders, fascias and the connection of these components. The full strength of trusses is not achieved until all components are installed correctly. All trusses must be braced (temporary and permanently) and stabilised throughout installation of the roof truss system. No truss should be loaded until all permanent bracing is fixed and battens/purlins are installed. Installers should not stand on any truss until all temporary bracing is fixed in place and the truss is stabilised in accordance with the following instructions.
3. A risk assessment shall be undertaken for each site taking into account all relevant workplace safety practices, including working height. It is the builders responsibility to consider the site conditions when determining procedures for handling, lifting, fixing and bracing of roof components. The procedures shall be discussed with all employees and sub contractors working on site and the agreed methods documented. A useful template for this purpose is the "Safe Working Method Statement No. 10" which is published by the Housing Industry Association (HIA) and available on their website. "The National Code of Practice for the Prevention of Falls in Housing Construction" produced by Safe Work Australia contains specific information and guidance on risk management for working at height in the residential construction sector. All safety gear appropriate to the site and work being carried out shall be worn, including eye protection, foot protection and gloves when handling sharp edges.
4. Ensure all bracing is permanently fixed and all brackets are fully installed prior to working on or loading the roof.
5. Trusses are designed for specific loading, geometry and support conditions. Under no circumstances should any component of the truss be drilled, cut, removed or modified in any way without prior approval from the truss fabricator.
6. Trusses should not be used or stored where they are subjected to repeated wetting and drying as this has a detrimental effect on the strength of both timber and connections.
7. If trusses have been designed for timber fascias, do not replace with steel fascia without asking your truss supplier to check the overhang design.

TRANSPORT

Trusses must be fully supported when being transported in either a horizontal or vertical plane. Care must be taken when tying down, not to put strain on chords or webs.

Timber or metal right angle protectors are a satisfactory method of avoiding damage. Unloading and handling is described opposite.

JOB STORAGE AND LIFTING

Trusses should be inspected on arrival at site. Any damaged trusses should be reported immediately and not site repaired without approval of the truss fabricator.

Where it is anticipated that trusses will be stored on site for an extended period of time before use, adequate provision should be made to protect trusses against the effects of weather.

Once trusses are installed they should not be left exposed to weather for long periods. Repeated wetting and drying has a detrimental effect on the strength of both timber and connection.

Protective covering, where used, should allow free air circulation around trusses.

Trusses when stored on the job site should be on timber fillets clear off the ground and in a flat position to avoid distortion.

When lifting, care must be taken to avoid damaging of joints and timber. Spreader bars with attachment to the panel points should be used where span exceeds 9000 mm. Never lift by the apex joint only.

The trusses may also be placed on the top plates by pulling them up on skids, spread at 3000 mm, taking the same precaution as described above.

Ensure that the trusses are not distorted or allowed to sag between supports.

The recommended method of lifting trusses will depend on a number of factors, including truss length and shape.

In general, sling truss from top chord panel points as shown below. Slings should be located at equal distance from truss centreline and be approximately 1/3 to 1/2 truss length apart.

The angle between sling legs should be 60° or less and where truss spans are greater than 9000 mm a spreader bar or StrongBack should be used. Some typical examples are shown below.

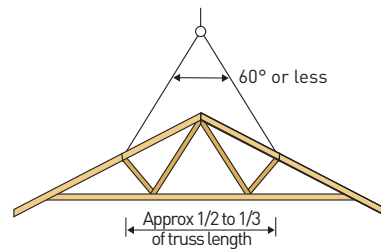

RT001-a

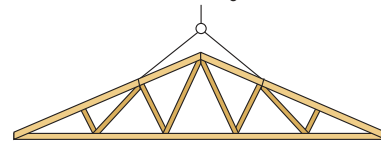

RT001-b

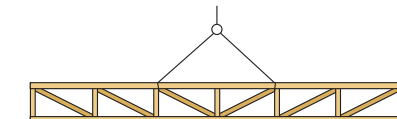

RT001-c

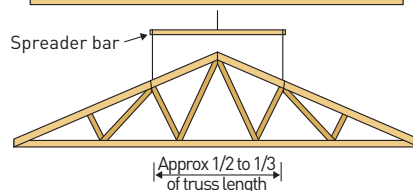

RT001-d

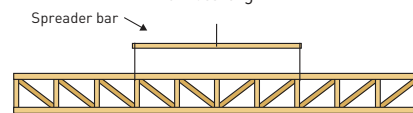

RT001-e

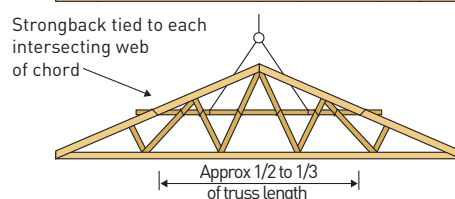

RT001-f

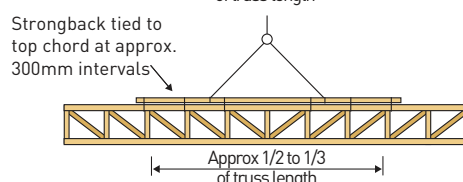

RT001-g

ROOF LAYOUT

A layout for trusses must be determined before erection. If in doubt consult your truss fabricator.

Points circled on these layouts may be critical. Refer to the Wall Frame Construction notes.

Hip End

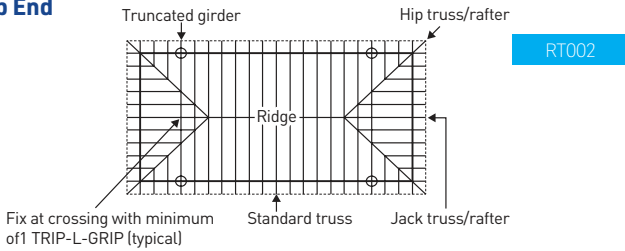

Dutch Hip

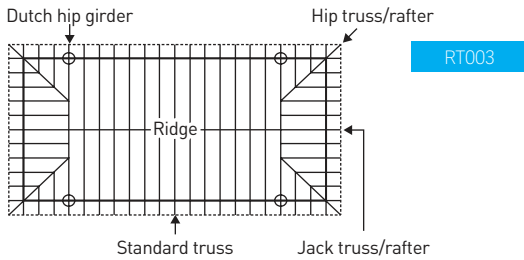

Gable

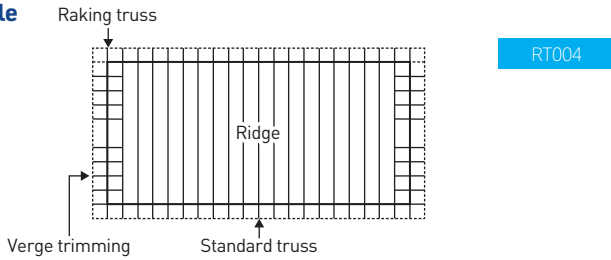

NOTE: End gable truss to be located over end wall unless otherwise advised by supplier.

T Shaped

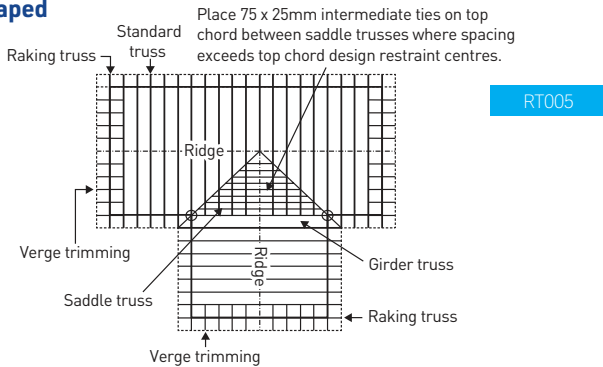

L Shaped

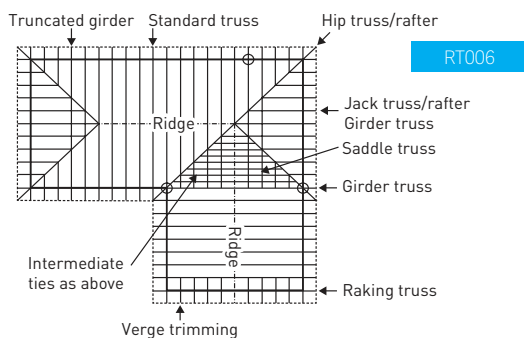

Gable Ends

Where a gable end is required, consult your truss fabricator for details of construction and erection.

SUPPORTING STRUCTURE (FRAME OR BRICK)

A structure that is not level and is out of square will result in an ugly and unsatisfactory roof line. Time is well spent in ensuring:

1. The load bearing top plates are level.
2. The structure is of the correct dimension.
3. The top plates as well as being level, are straight in their length.
4. The internal walls are set below the outer wall level by: Unbattened ceiling – 10mm. Battened ceiling – 10mm plus batten thickness.

NOTE: For 900mm spaced trusses, plasterers prefer to use 50mm battens.

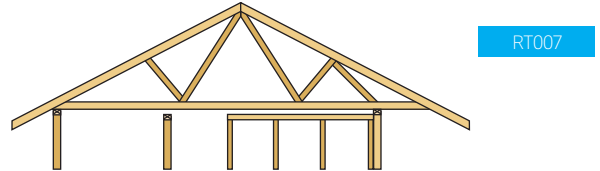

WALL FRAME CONSTRUCTION

The load bearing frames should be checked for:

1. Lintel sizes suitable for truss loading. Consult AS 1684 or your truss fabricator.
2. If trusses are not located directly over studs the top plate size must be in accordance with AS 1684.
3. Girder trusses may require the strengthening of studs at the points of support. Check the loading with your truss fabricator and refer to AS 1684. Points circled on the layout notes are critical.

The supporting structure construction must be adequate to resist wind up-lift forces.

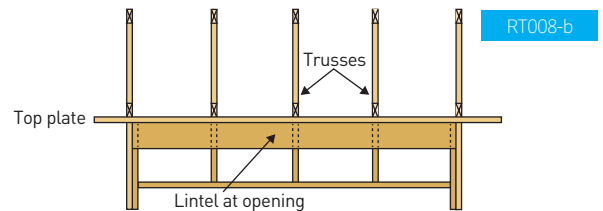
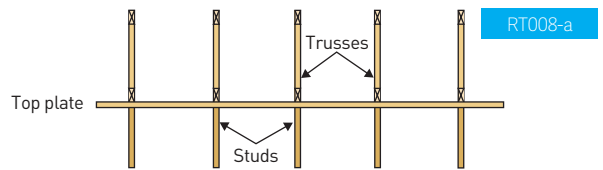

Top plate strengthening may be required where trusses do not coincide with studs.

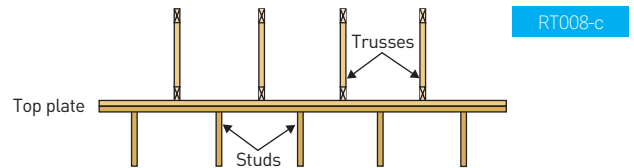

FRAME BRACING

The frame must be fully braced, plumb, and nailed home before the erection of trusses is commenced.

ERECTION AND FIXING

It is convenient to mark the truss position on the wall plates before lifting trusses. Use the layout drawing as your guide and note that the truss design spacing must not be exceeded.

Ensure first truss is installed carefully and within erection tolerances.

WARNING – Do not use web as ladder to climb up or down the roof during installation. This can cause damage to the web and lead to serious injury.

GABLE ROOFS – start with a gable truss at each end, fixing it to the top plate at the position marked. These trusses must be temporarily braced back to the ground or frame at the panel points.

HIP OR DUTCH GABLE – start with the Dutch girder truss or the truncated girder, placing it on the top plate at the position marked and temporarily bracing it back to the frame. Locate hip and jack trusses and adjust girder truss position before fixing.

LINE – Using a stringline along the Apex, place each intermediate truss and fix it to the top plate at the position marked, spacing it with gauging rods and ties.

RT009

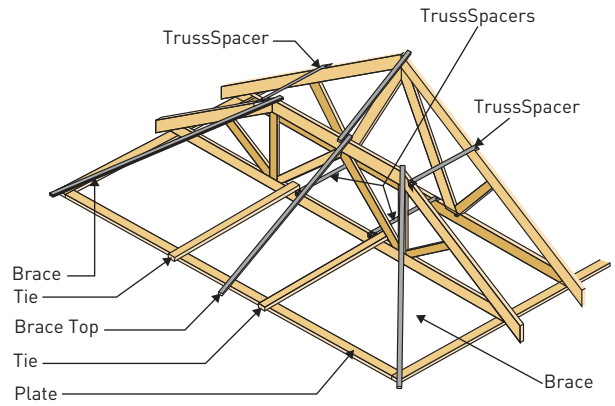
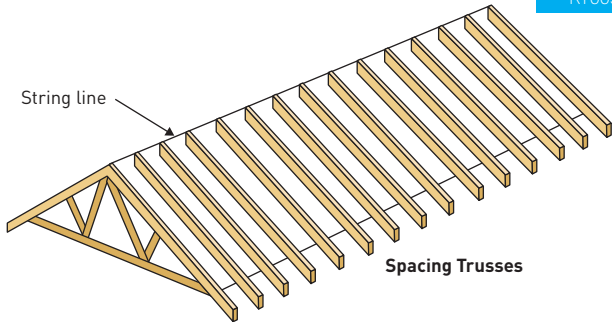

CAMBER

Trusses are built with a camber in the bottom chord. The camber is designed to suit the span and load. A girder truss will have more camber than other trusses. The camber is progressively taken up as the load from the roof covering and ceiling is applied. Under no circumstances should trusses be supported along the span (unless designed for) by blocking or propping.

If a truss has been designed to be supported internally a "SUPPORT HERE" label is affixed to the appropriate point.

RT010

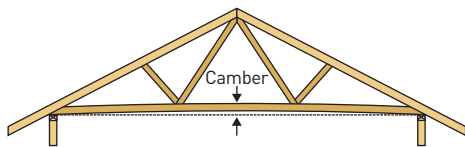

ERECTION BRACING

The trusses must be braced during erection. If this is not done, then two problems can occur.

1. Collapse during erection.
2. Erection tolerance will be exceeded, causing overloading, buckling and possible permanent damage.

The exact details of erection bracing will, for practical purposes, differ from job to job. The following recommendations are for guidance only as the details employed are the erectors responsibility.

The first truss should be erected straight and plumb to erection tolerances given previously and temporarily braced to a rigid element, e.g. wall or ground as shown on diagram following.

RT011

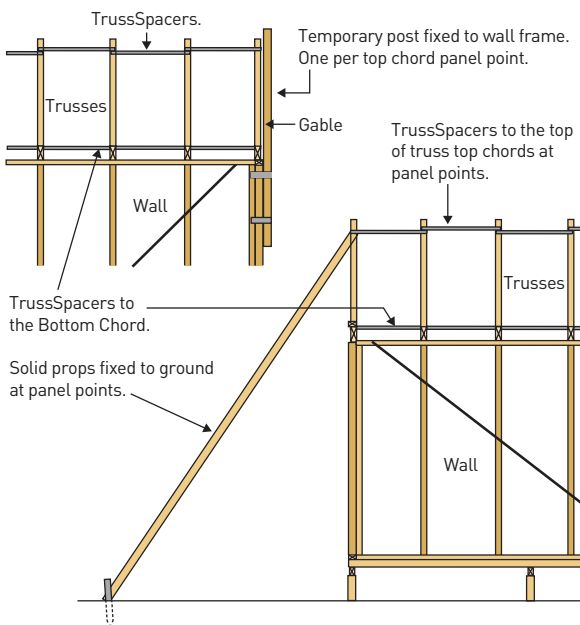

Each successive truss should be spaced using TrussSpacers. TrussSpacers are recommended in lieu of gauging rod or timber ties, as these can be fixed to the trusses prior to lifting trusses on to top plates. If timber ties are used, they must be continuous and be no less than 70 x 35 F5. Fix to each truss with a minimum of one 65mm nail and splice the ends by lapping over two adjacent trusses. Short timber noggings between trusses are not acceptable.

Do not stand on a truss that does not have all its TrussSpacers or temporary ties fixed.

The purpose of temporary bracing is to hold trusses straight and plumb prior to fixing permanent bracing. All permanent bracing, ties, hold down, etc. must be fixed prior to loading roof.

CODE REQUIREMENTS

Australian Standard for the installation of nailplated trusses AS 4440 requires that temporary ties are to be used on top chords at spacings no greater than 3000mm and on bottom chords at spacings no greater than 4000mm. However, it is good practice to place top chord ties at each top chord panel point.

The TrussSpacer is designed to replace the temporary chord ties as required by AS 4440. To conform with AS 4440 requirements use TrussSpacers as below.

Standard layout

RT013

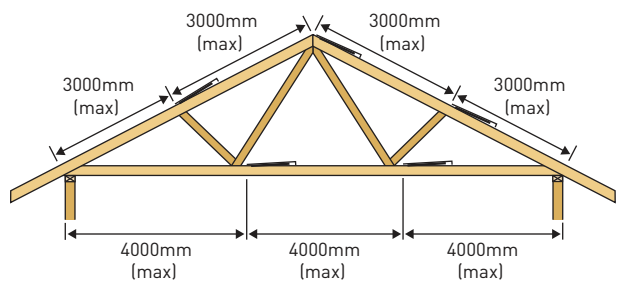

Alternative layout

RT014

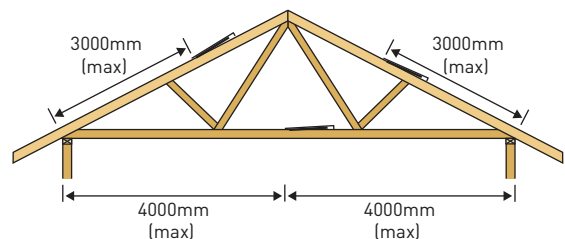

See TrussSpacer Installation Instructions for further information.

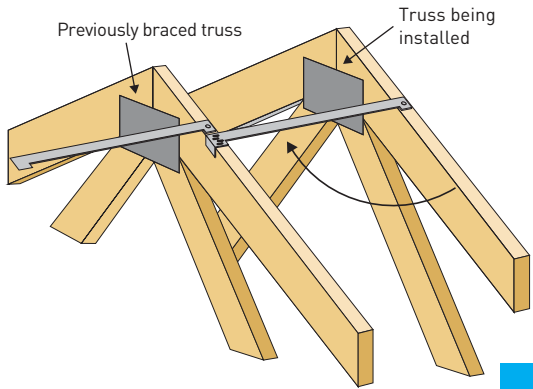

RT015

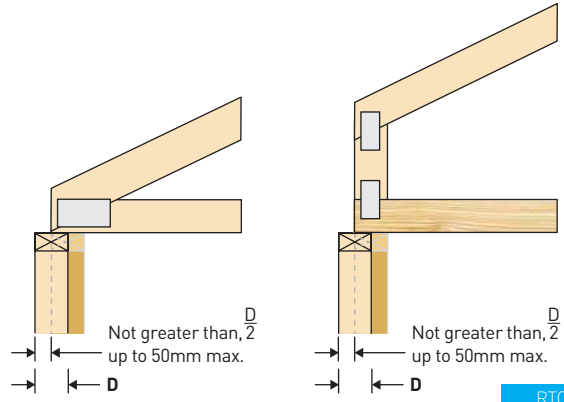

RT018

TrussSpacer: GTS600 for 600mm centres, GTS900 for 900mm centres.

Important Note

These recommendations are a guide only for the erection of standard gable trusses up to 13000mm span, and spaced at centres not exceeding 1200mm. For trusses beyond these conditions, consult your truss fabricator.

ERECTION TOLERANCES

Tolerance is critical for both a good roof line and effective bracing. A stringline, a plumb line or level should be used.

1. Trusses to be erected with minimal bow, in the truss and in any chord, with a tolerance not exceeding the lesser of $L/200$ and 50mm, where L is as defined as shown in diagrams.
2. Trusses to be erected so that no part of the truss is out of plumb with a tolerance exceeding the lesser of $height/50$ and 50 mm.

Generally if a bow or tilt is evident to the eye, the truss has been erected outside the tolerances.

Internal Support

The maximum allowable tolerance at internal support is 100mm.

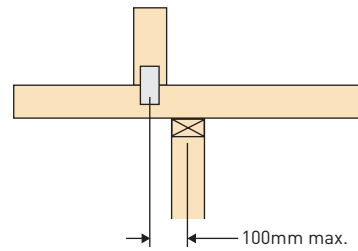

RT019

Overhang Supported

For overhang supported truss, the maximum tolerance is half the wall thickness, up to 50mm. Check bearing strength where bearing area is reduced.

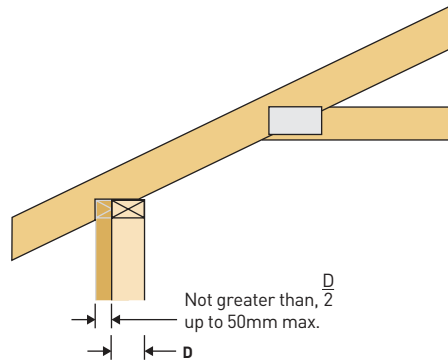

RT020

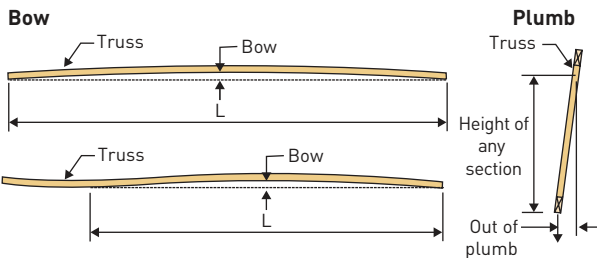

RT016

SUPPORT TOLERANCES

Support at heel /cut-off

When truss heel or end of cut-off truss extends over support with no reduced bearing, the maximum tolerance is 50mm.

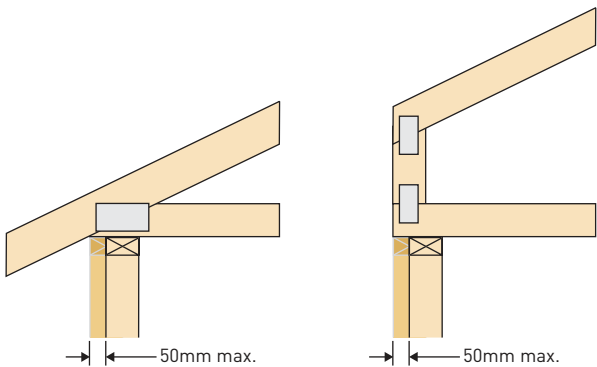

RT017

When truss heel or end of cut-off truss is shorter than wall support, the maximum tolerance is half the wall thickness, up to 50mm. Check bearing strength where bearing area is reduced.

FIXING TO TOP PLATE

Internal or non-load bearing walls

(a) Non-Bracing Wall

If internal or non-load bearing walls are not designed as bracing walls, fix the truss with the InternalWall Bracket with nails to middle of slots to allow for truss settlement as it is loaded. Brackets are fixed at 1.8m centres along unsupported sections of the wall. Where trusses are parallel to walls, trim between the bottom chords and fix brackets to the trimmer. Where non-load-bearing walls are stable in their own right, no InternalWall Brackets are required.

Trusses parallel to non-bracing wall

RT021-a

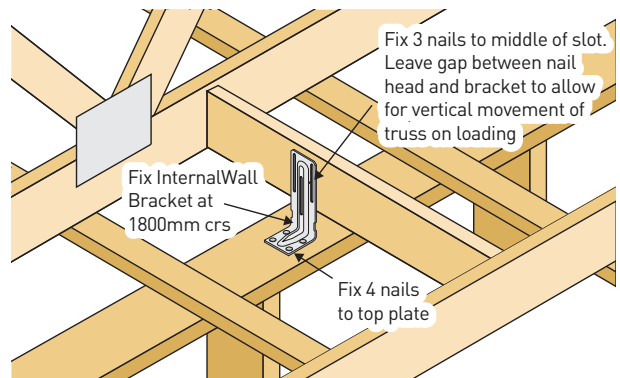

Trusses at right angle to non-bracing wall

RT021-b

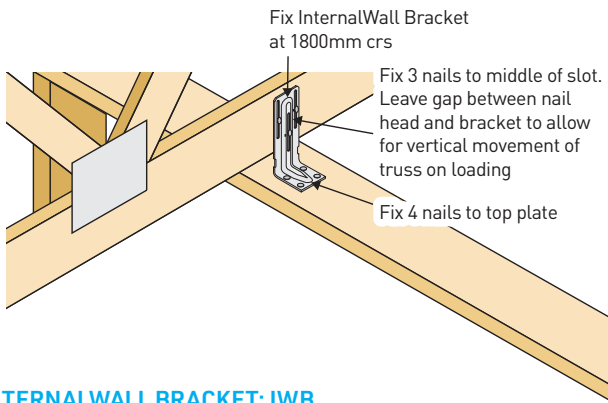

INTERNAL WALL BRACKET: IWB

(b) Bracing Wall

When internal non-load bearing walls are designed as bracing walls, trusses should be fixed to top plate using BraceWall Brackets according to Table 1 and as follows.

Trusses at right angles to bracing wall

RT022

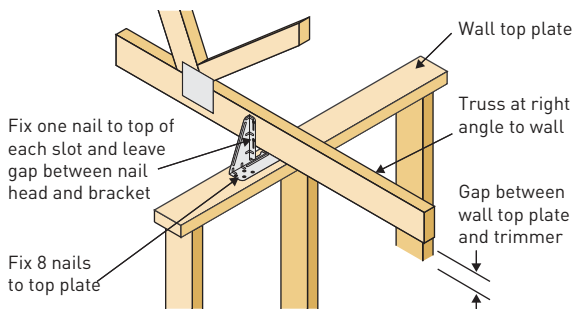

Trusses parallel to bracing wall

RT023

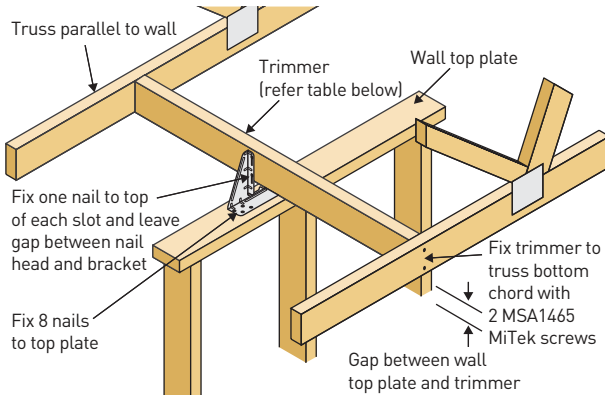

BraceWall Bracket: BWB35

Trimmer Size (mm x mm)	Minimum Grade	Maximum Truss Spacing (mm)
90 x 35	MGP10	600
90 x 35	MGP12	900
120 x 35	MGP12	1200

Table 1 - Fixing requirements for top of bracing walls

Bracing Length (m)	Number of BraceWall Brackets (BWB35)								
	For bracing walls rated at (kN/m) capacity								
	1.5	2.0	3.0	3.5	5.5	6.0	6.5	7.5	9.0
0.6	1	1	1	1	1	1	2	2	2
0.9	1	1	1	1	2	2	2	2	3
1.2	1	1	1	2	2	2	3	3	3
1.5	1	1	2	2	3	3	3	4	4
1.8	1	1	2	2	3	3	4	4	5
2.1	1	2	2	3	4	4	4	5	6
2.4	1	2	2	3	4	4	5	5	6
2.7	2	2	3	3	5	5	5	6	7

(c) Non-Load Bearing External Wall

For non-loadbearing external walls, such as verandah walls where trusses are pitched off verandah beams or other beams, the top plate of the wall should be stabilized at maximum 3000mm centres as shown.

RT024

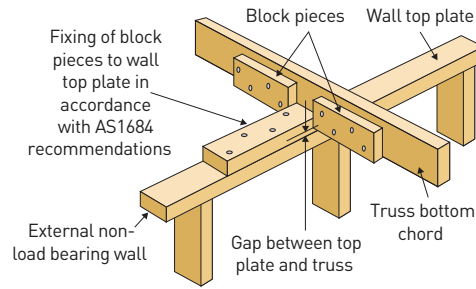

External or load bearing walls

Each end of the truss should be fixed to the top plate in accordance with recommendations on page 19.

FIXING TO GIRDER TRUSSES

Special Girder Brackets are available for supporting standard trusses on the bottom chords of Girder Trusses. These brackets should be fully fixed in accordance with details supplied by the truss fabricator prior to loading roof. (Refer page 22).

FIXING OF VALLEY (SADDLE) TRUSSES

Connection of valley (saddle) trusses to be in accordance with details supplied by the truss fabricator or those in AS 4440.

FIXING OF MULTIPLE PLY TRUSSES

Multiple ply trusses are required to be joined in accordance with the following recommendations to comply with design assumptions.

Standard, truncated and hip trusses

Double Truss (nail one side only)

Join all chords and webs with nails or screws staggered one side only. *Nails or screws to be at 300mm centres for top chords and 450mm centres for bottom chord and webs.

RT025-a

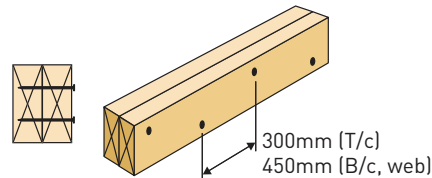

Triple Truss

(nail both sides with bolts or screws at panel points)

Join outer trusses to centre truss using the double truss details. In addition, join trusses at each panel point with one M12 bolt or alternatively with two sufficiently long No. 14 screws from each side (i.e. 4 screws at each panel point).

RT025-b

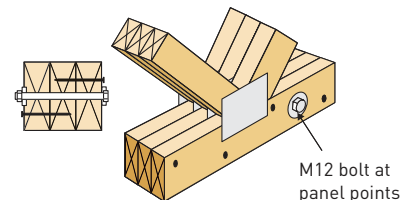

GIRDER AND DUTCH HIP GIRDER TRUSSES

Nail or screw as for standard trusses except maximum nail or screw centres to be 300mm to all chords and webs.

Waling plate to be fixed to each Dutch Hip girder chord and web crossing with nails, screws or bolts in accordance with M2RS-0008.

If screws are used in FastFit MkIII and MKIV Girder Bracket, use 65mm screws in double 35mm girder. With triple 35mm ply girder, use 65mm screws in bracket and fix additional 65mm screws in back of girder truss behind bracket. Use 3 screws for FastFit MkIII and 8 screws for FastFit MKIV Girder Bracket. Alternatively, use 100mm No. 14 Type 17 hex head screws in bracket. With multiple 50mm ply girder, use bolts or longer screws.

Nailing Details: (all truss types)

Nails:

Use 3.05mm diameter glue coated or ring shank nails, minimum 65mm long for truss thickness up to 38mm or 75mm long for truss thickness up to 50mm

Nails - Bolts:

Use M12 bolts with 50 x 50 x 3.0mm square washers or 55 dia. x 3.0mm round washers.

Screws:

Use No. 14 gauge x 65mm long up to 38mm timber or 75mm long up to 50mm timber.

For further information refer to MIRS-0020.

*Ensure all fasteners are fixed before loading roof.

GABLE END FIXING

There are a number of different ways in which gable ends and verge overhangs can be constructed. These include:

- Cantilevered Battens
- Underpurlins
- Outriggers over Raking Truss
- Verge Sprockets

The selection of a particular method will depend on a number of factors including verge overhang distance, roof and ceiling material, truss spacing, end wall construction, wind load and preferred local building practice and cost. The following are typical details for each fixing method. For connection details refer to MIRS-0016

CANTILEVERED BATTENS

RT026-a

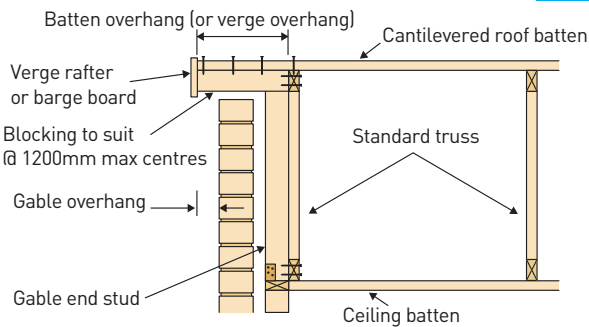

UNDERPURLINS

RT026-b

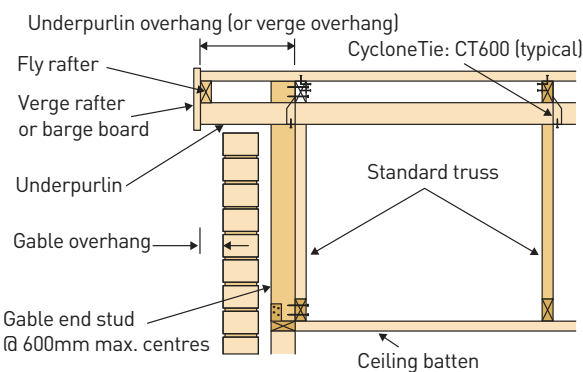

OUTRIGGERS OVER RAKING TRUSS

RT026-c

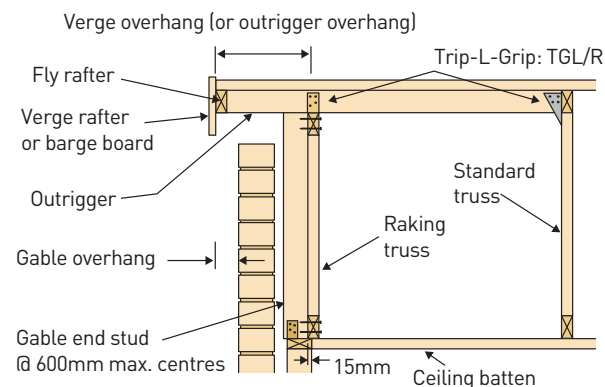

VERGE SPROCKETS

RT026-d

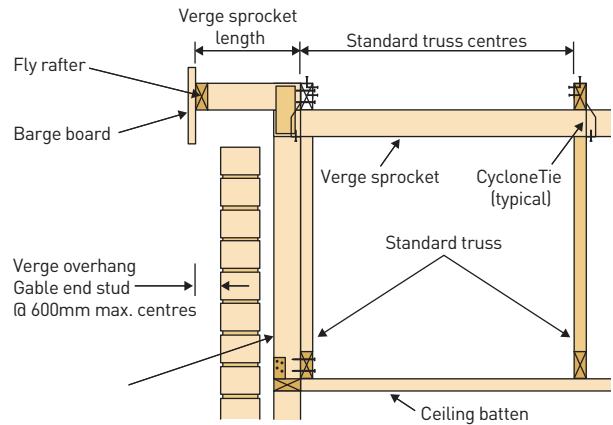

HIP END FIXING

The fixing details in this section are suitable for trusses with maximum spacing up to 900mm (or 1200mm for sheet roof up to N3), snow load up to 0.2kPa and 3600mm maximum truncated girder station. For other applications exceeding these limits, refer to connections detailed in the MiTek 20/20 design output.

Notes

1. These connections are adequate, based on general domestic construction practices which include at least two 2.5mm skew nails, with a penetration of 10 times of nail diameter to supporting member, connecting each member.
2. Nail details may be substituted by screws with equivalent capacity.
3. These details are also applicable for use in conjunction with conventional hip ends.

For Wind Classification N1, N2, N3 or C1

Connection of trusses at hip end for wind classification N1, N2, N3 or C1 are in accordance with the details shown and described in Figure 1 and Detail A1 to E1.

Figure 1. Typical trussed hip end connection for Wind Classification N1, N2, N3 or C1

RT027

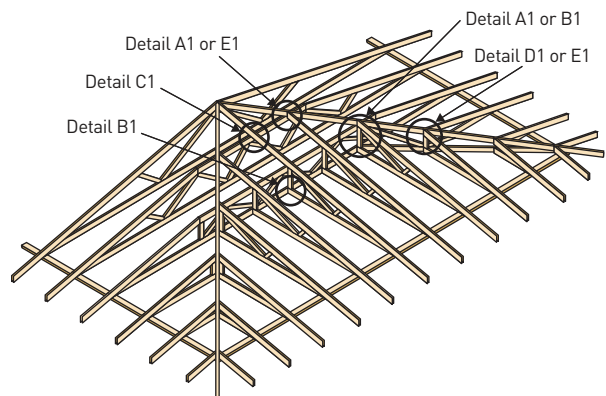

Notes

1. For effective skew nailing, the nail shall be driven into one member not closer than 25mm to no more than 38mm from the arris in contact with the adjacent member. The nail shall be driven at an angle between 30° and 45° to the face into which the nail is driven.
2. Where nails are smaller than the nominated size or other than plain shank nails, or machine driven, or both, their performance shall not be inferior to the nail size given.
3. Roof battens or purlins and ceiling battens shall be fixed to trusses in accordance with approved specifications.

Detail A1 - Hip Truss to Truncated Girder Truss

RT028-a

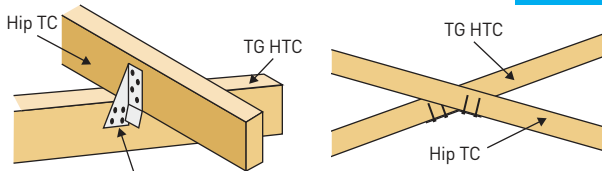

One Trip-L-Grip (TGL/R) bent to suit, with 4 MiTek 30mm x 2.8mm reinforced head nails to each top chord

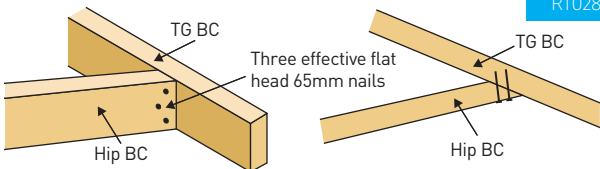

RT028-b

Detail B1 - Jack Truss to Truncated Girder Truss

RT029

One Trip-L-Grip (TGL/R) bent to suit, with 4 MiTek 30mm x 2.8mm reinforced head nails in to the side of each top chord and 2 MiTek 30mm x 2.8mm nails to the top of truncated girder horizontal top chord

Note: For wind classification N2 and tile roofs, truncated girder with spans up to 8000mm and station up to 2400mm, detail C1 may be used.

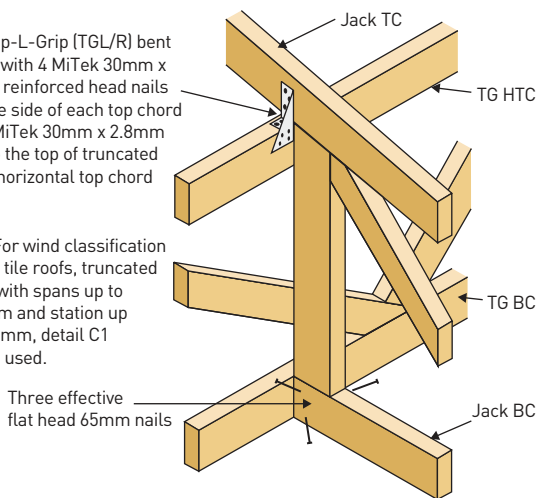

Three effective flat head 65mm nails

Detail C1 - Extended Jack or Hip Truss to top chord of Truncated Standard Trusses

RT030

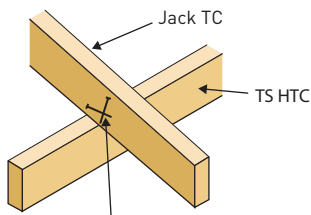

Two 65mm skew nails into the side of each top chord

Detail D1 - Jack Truss to Hip Truss (maximum jack station 1800 mm)

RT031

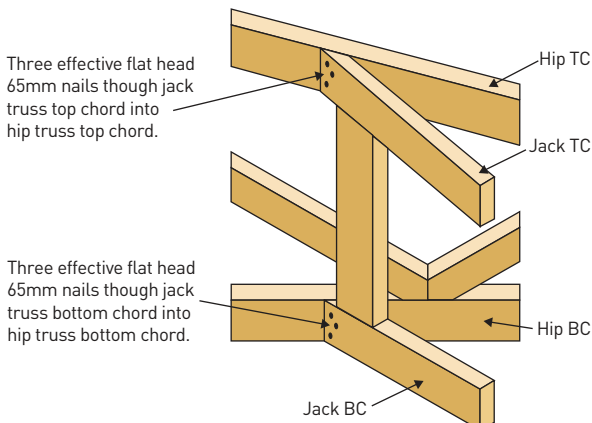

Three effective flat head 65mm nails though jack truss top chord into hip truss top chord.

Three effective flat head 65mm nails though jack truss bottom chord into hip truss bottom chord.

Detail E1 - Jack Truss to Hip Truss (maximum jack station 3000 mm)

RT032

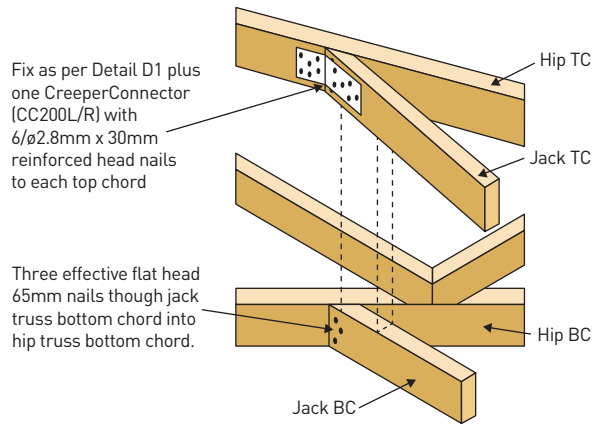

Fix as per Detail D1 plus one CreeperConnector (CC200L/R) with 6/ø2.8mm x 30mm reinforced head nails to each top chord

Three effective flat head 65mm nails though jack truss bottom chord into hip truss bottom chord.

For Wind Classification N4, C2 or C3

Connection of trusses at hip end for wind classification N4, C2 or C3 are in accordance with the details shown and described in Figure 1 and Detail A2 to E2.

Figure 2. Typical trussed hip end connection for Wind Classification N4, C2 or C3

RT033

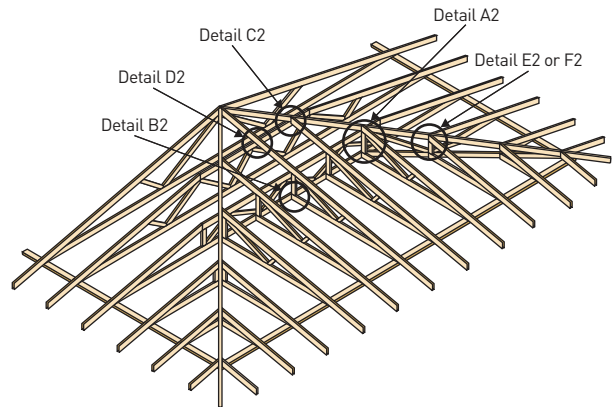

Notes

1. For effective skew nailing, the nail shall be driven into one member not closer than 25 mm to no more than 38 mm from the arris in contact with the adjacent member. The nail shall be driven at an angle between 30° and 45° to the face into which the nail is driven.
2. Where nails are smaller than the nominated size or other than plain shank nails, or machine driven, or both, their performance shall not be inferior to the nail size given.
3. Roof battens or purlins and ceiling battens shall be fixed to trusses in accordance with approved specifications.
4. Jack trusses are assumed to be supported in the horizontal top chord of the truncated girder.

Detail A2 - Hip Truss to Truncated Girder Truss

RT034

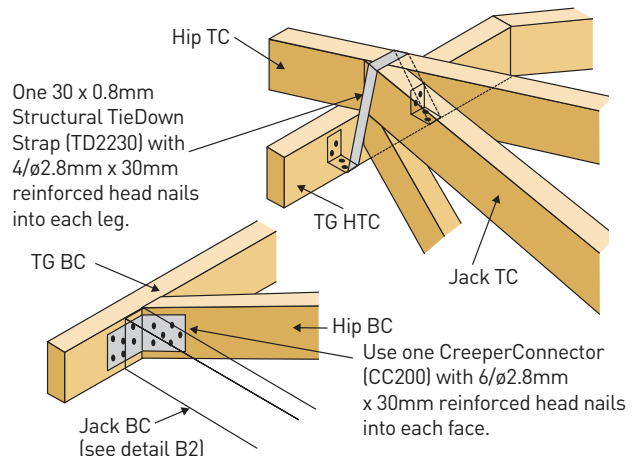

One 30 x 0.8mm Structural TieDown Strap (TD2230) with 4/ø2.8mm x 30mm reinforced head nails into each leg.

Use one CreeperConnector (CC200) with 6/ø2.8mm x 30mm reinforced head nails into each face.

Detail B2 - Jack Truss to Truncated Girder Truss

RT035

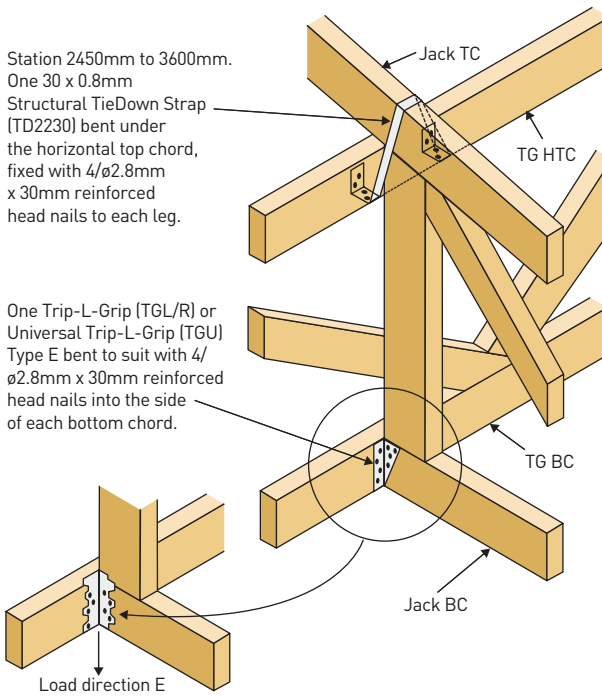

Detail E2 - Jack Truss to Hip Truss (maximum jack station 2400mm)

RT039

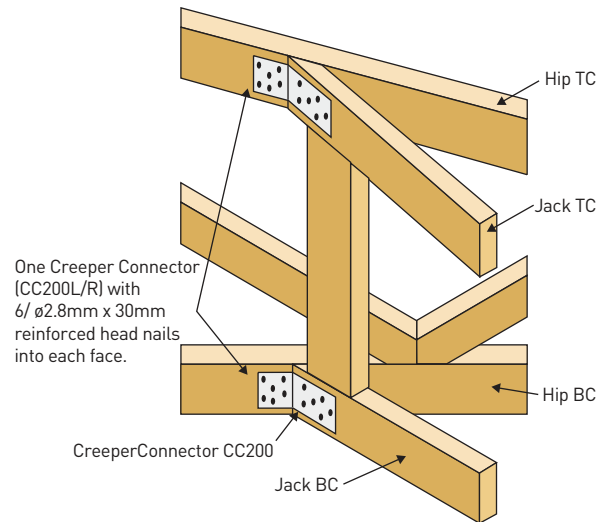

Detail F2 - Jack Truss to Hip Truss (maximum jack station 3000mm)

RT040

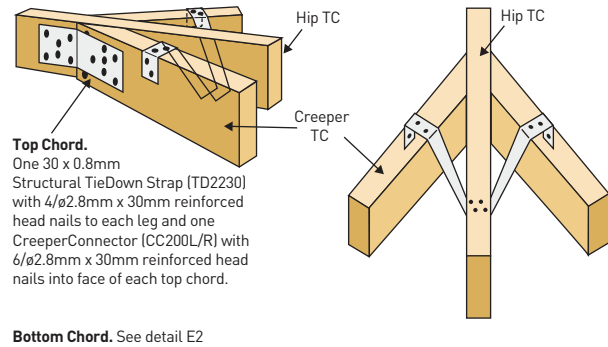

RT036

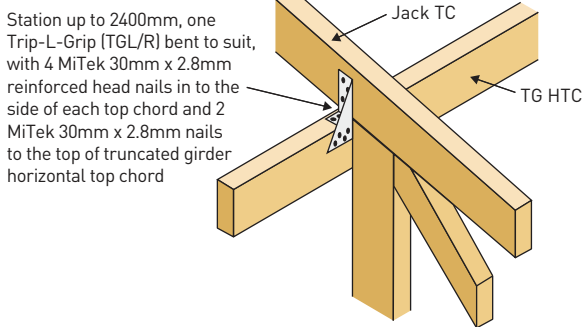

Detail C2 - Intersection of Jack and Hip Truss to Truncated Standard Truss

RT037

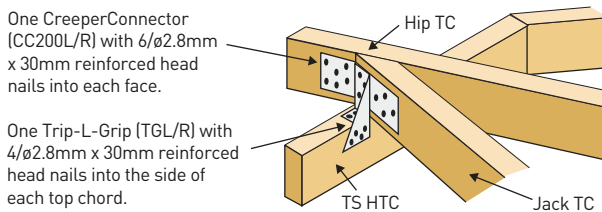

Detail D2 - Extended Jack or Hip Truss to top chord of Truncated Standard Trusses

RT038

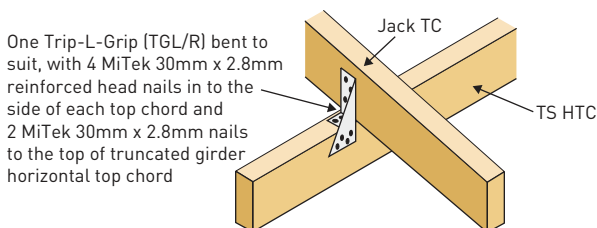

CREEPERCONNECTORS

CreeperConnectors have been designed to connect jack trusses to hip trusses. They may be used wherever a mitre plate is specified in AS 4440.

RT041

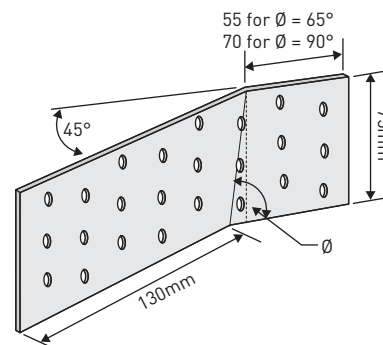

CC200 CreeperConnector ($\theta = 90^\circ$)

Suitable for low pitch roofs or for bottom chord connection. That is, pitches 0° to 12.5° pitched chords.

CC200R and CC200L CreeperConnectors ($\theta = 65^\circ$)

Suitable for pitches from 13° to 25° and that suffix L and R defines that the product is designed for left hand or right hand connection.

Fixing Detail for Double Mitred Truss

Single mitre and square cut ends are not suitable for this method.

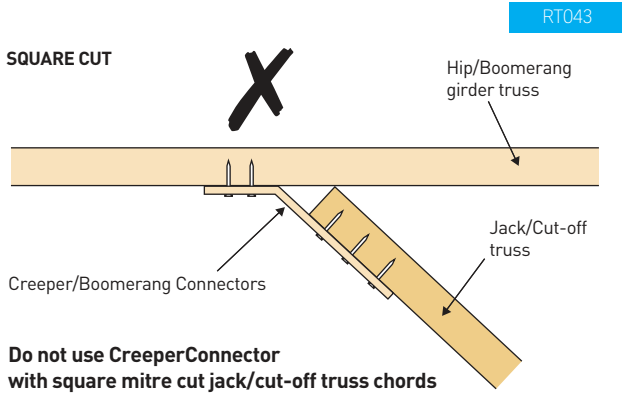
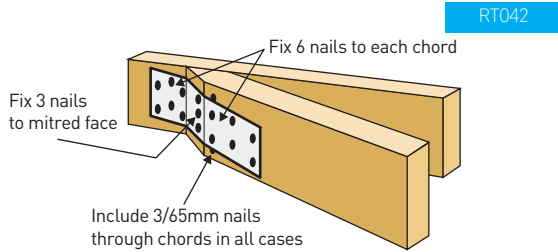

BOOMERANG CONNECTOR (BC200)

The Boomerang Connector has been developed to provide a strong and economical connection between cut-off trusses and boomerang girders, or between large jack trusses and hip trusses.

Table 2 gives the maximum span recommendations of jack/cut-off truss connected to the hip/boomerang girder truss with a Boomerang Connector.

Table 2. Maximum Jack/Cut-off Truss Span (m)							
Joint Group	Wind Classification						
	N2	N3	N4	N5	C1	C2	C3
Sheet roof, 20° roof pitch & plaster ceiling @900mm crs							
JD3	16.0	16.0	10.3	6.3	9.3	5.8	3.9
JD4	16.0	16.0	10.3	6.3	9.3	5.8	3.9
JD5	15.5	15.5	10.3	6.3	9.3	5.8	3.9
Concrete tile, 20° roof pitch & plaster ceiling @600mm crs							
JD3	16.0	16.0	16.0	11.8	16.0	10.2	6.3
JD4	15.8	15.8	15.8	11.8	15.8	10.2	6.3
JD5	12.2	12.2	12.2	11.8	12.2	10.2	6.3

INSTALLATION

Single Fold Fixing Method

Suits single or double mitred jack/cut-off truss with skew angle from 30° to 80°.

1. Locate jack/cut-off truss into position and fix 3/75mm nails through each top and bottom chord to the hip/boomerang girder truss.

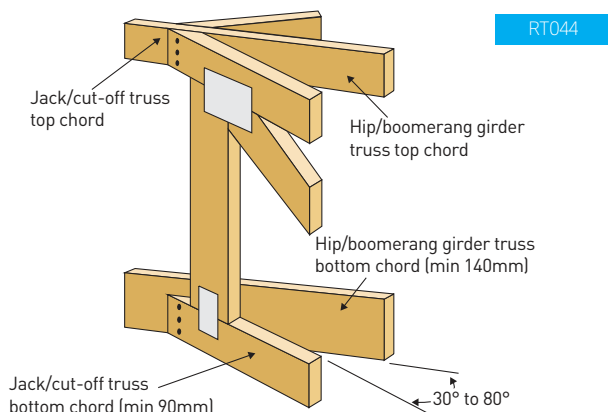

2. With the short leg against the girder, align the Boomerang Connector with the incoming truss with a 6mm offset above bottom edge of the bottom chord. If necessary, bend the Boomerang Connector to the skew angle before aligning.

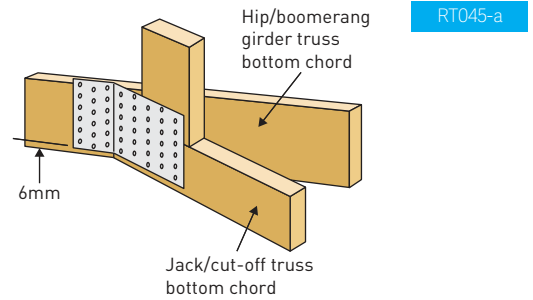

3. Ensure the connector is flush with the chord surface and fix 15 nails into the hip/boomerang girder bottom chord and 15 nails into vertical web and bottom chord of the jack/cut-off truss.

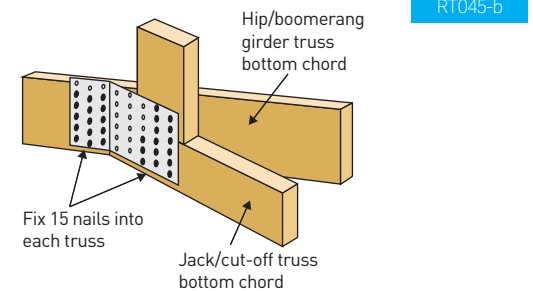

Double fold fixing method

Suits double mitred jack/cut-off truss with skew angle from 17° to 30°. Single mitre and square cut ends are not suitable for this method.

1. Locate jack/cut-off truss into position and fix 3/75mm nails through each top and bottom chord to the hip/boomerang girder truss.

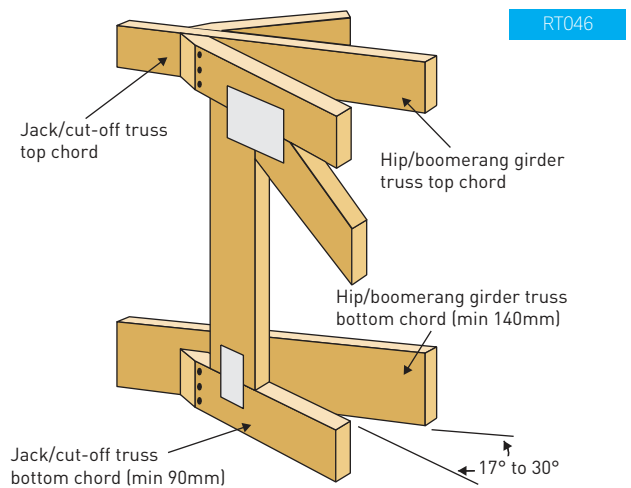

2. With the short leg against the girder, position the bend line along the tip of the double mitre. Offset 6mm above the bottom of the bottom chords.

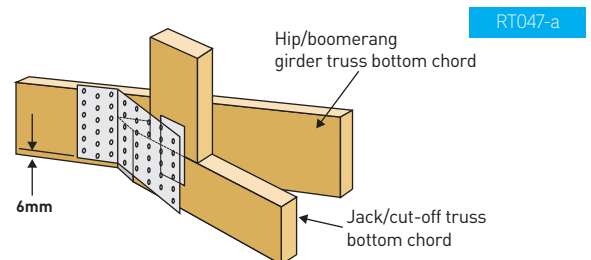

3. Fix 15 nails into the hip/boomerang girder bottom chord.

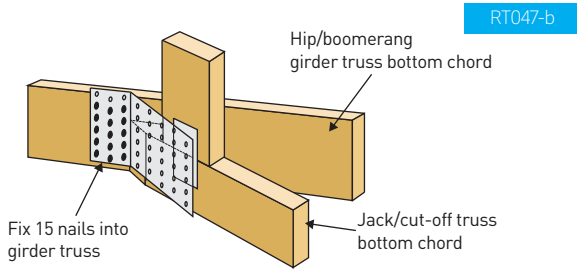

4. Wrap the Boomerang Connector around the mitre cut face and fix 3 nails into the mitre fold.

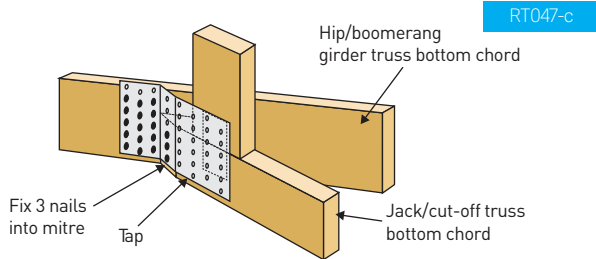

5. Further wrap the connector flush with the jack/cut-off truss. Then fix another 15 nails into the vertical web and bottom chord of the jack/cut-off truss.

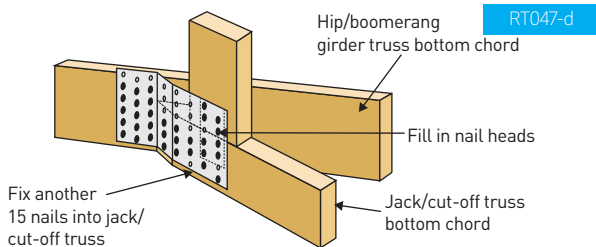

SADDLE TRUSS FIXING

The fixing details in this section are suitable for trusses with maximum spacing up to 900mm (or 1200mm for sheet roof up to N3). For trusses supporting sheet roof up to 1200mm truss spacing and up to N4 or C3 wind classification, substitute the fixing details between saddle truss and supporting truss with details in Table 3. For other applications exceeding these limits, specific design is required.

Wind Classification	Fixing Details
N1, N2, N3 & C1	1 x Universal Trip-L-Grip
N4, C2 & C3	2 x Universal Trip-L-Grips, or 1 x CycloneTie CT400 plus 1 x 65mm skew nail

FOR WIND CLASSIFICATION N1, N2, N3 or C1

Roof Pitch $\leq 15^\circ$

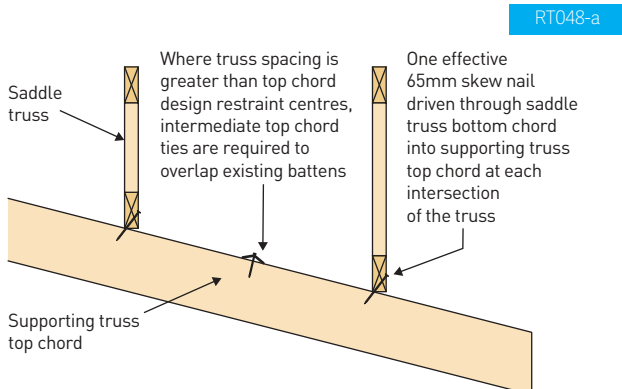

Roof Pitch $> 15^\circ$

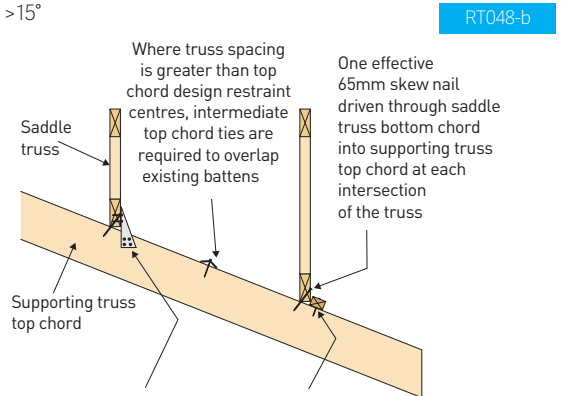

Alternatively, one Trip-L-Grip (TGL/R) fixed with 4/ø2.8 nails to each face, without timber ledge

35mm x 45mm timber ledge or block fixed to top chord

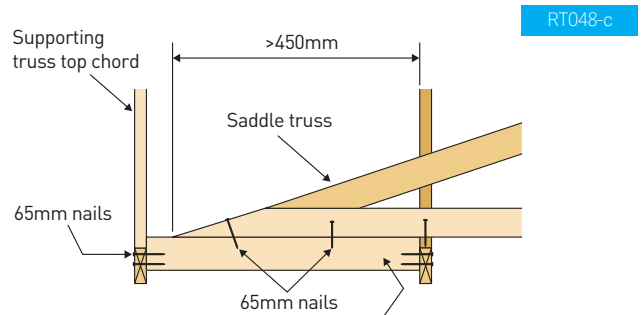

Block infill (minimum 75 x 35) to where the saddle truss is cantilevered more than 450mm or where the saddle truss is not supported by two truss top chords, fixed to the saddle truss bottom chord with 2/65mm nails, and to each end to supporting truss top chord with 2/65mm nails

FOR WIND CLASSIFICATION N4, C2 or C3 Supported Trusses Without A Ceiling

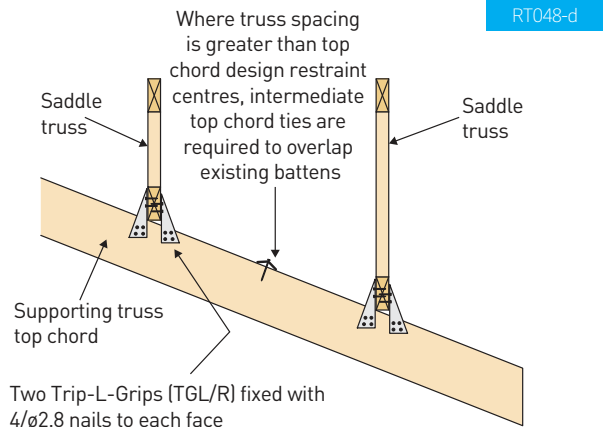

Two Trip-L-Grips (TGL/R) fixed with 4/ø2.8 nails to each face

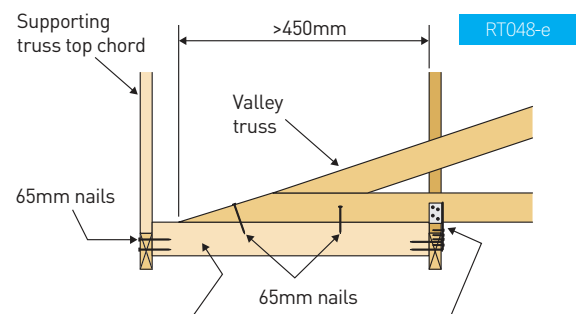

Block infill (minimum 75 x 35) to where the saddle truss is cantilevered more than 450mm or where the saddle truss is not supported by two truss top chords, fixed to the saddle truss bottom chord with 2/65mm nails, and to each end to supporting truss top chord with 2/65mm nails

One Trip-L-Grip with 4/ø2.8 nails to each face

Supported Trusses With A Ceiling

RT048-f

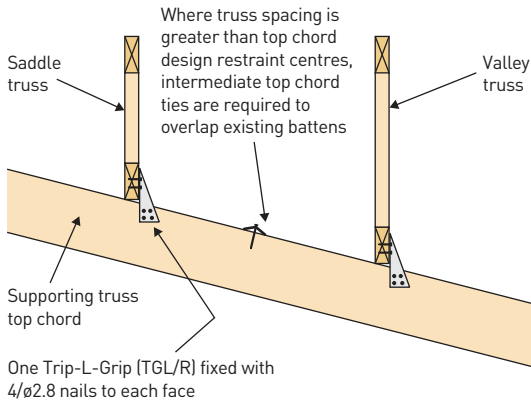

ROOFING BATTENS

The stability of any roof system is reliant on the tile or sheeting battens. The contract with the roofer should include the following provisions:

Roofing battens should be fixed securely to all truss top chords in accordance with AS 1684 unless otherwise specified by local building regulations. For multiple ply trusses, battens should be fixed securely to each ply of truss top chord with at least one nail or other mechanical fixing. Battens wider than 50mm should be secured with two fixings to each ply.

Battens to be arranged so that on any truss top chord, not more than 1 in 3 battens are spliced and no two splices are adjacent.

In the areas of roof not bounded on both sides by diagonal bracing, battens should be continuous, if not use "Batten Strapnails" to splice. Roof should not be loaded until all roofing battens are securely fixed.

WARNING: Some types of steel tile battens do not provide adequate lateral restraint to truss top chords. Before using steel tile battens obtain certification from your steel batten supplier confirming that their product will provide at least the same lateral restraint as timber battens.

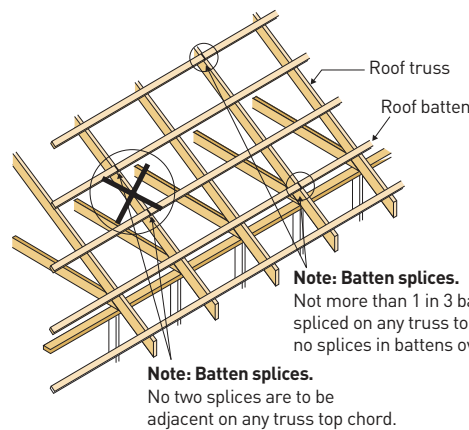

RT049

SPLICE DETAILS FOR ROOF BATTENS SUPPORTING SHEET ROOF

The splice details have been designed to resist axial loads on battens transmitted by truss top chord under the following criteria:

1. Standard trusses supporting sheet roof at 1200mm crs and 16000mm span maximum.
2. Maximum batten spacing = 1200mm
3. Batten size and grade to be in accordance with AS 1684 span tables. Batten splices should be typically located away from girder trusses. Use detail with stiffener as shown in Option 4.

Tie Downs -Batten to truss fixing should be checked for adequacy against tie-down requirement.

Note

Either bugle or hexagon head screw types can be used for all of the fixing options.

OPTION 1

RT050-a

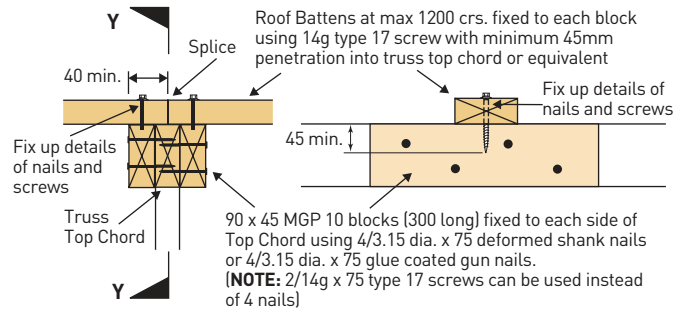

OPTION 2

RT050-b

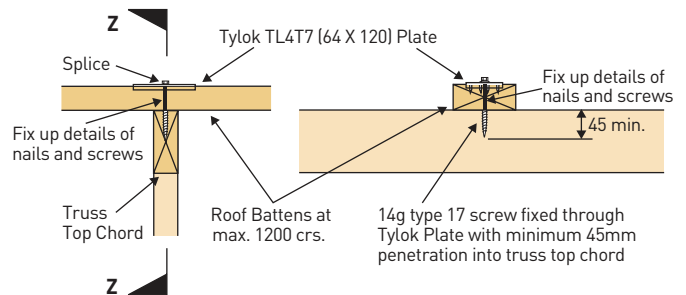

OPTION 3

RT050-c

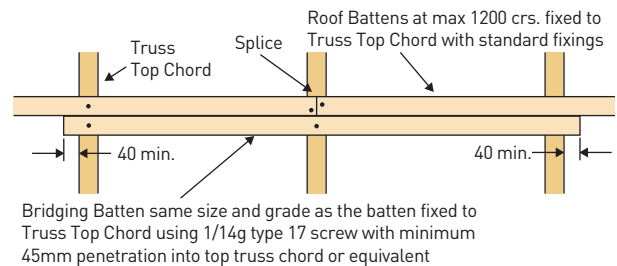

OPTION 4

RT050-d

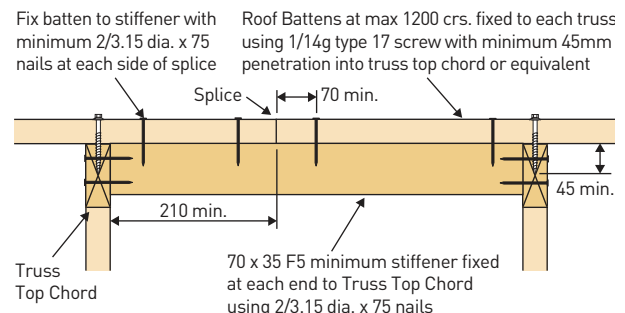

OPTION 5

RT050-e

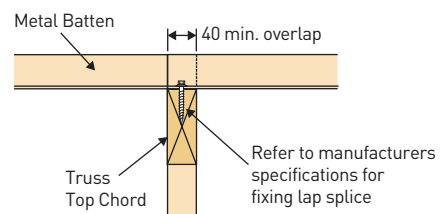

PERMANENT BRACING

Before loading, roof trusses must be permanently braced back to the rigid building element, such as support walls, to prevent rotation or buckling of trusses under the weight of roof and ceiling material or under wind uplift.

These recommendations provide for:

- Wind Classifications for areas up to C3.
- Walls being stable and braced in their own right.
- Roof spans up to 16000 mm.
- Maximum truss centres:
 - 900 mm in Wind Classification areas up to C3.
 - 1200 mm for sheet roofs in Wind Classification areas up to N3.
- Maximum roof pitch of 45°.

For conditions beyond these, consult your truss manufacturer.

SPEEDBRACE

SpeedBrace is a bracing system for the bracing of trussed roofs in both low wind speed and cyclone areas.

SpeedBrace is manufactured in accordance to AS 4440 steelbrace specification.

SpeedBrace is a tension bracing system that uses a pre-punched shallow 'V' shaped member that is easily handled and erected. SpeedBrace is applied in an 'X' or 'V' pattern to the top of the chord and braces the trusses back to the frame.

SpeedBrace offers many advantages over other bracing systems.

- Applied to top of top chord – speed and simplicity.
 - Pre-tension – no turnbuckles or similar device is required to tension the brace.
 - Maximum load is governed by end fixing and splicing which are to be made strictly in accordance with details shown in this publication.
 - Pre-punched – nailing made quick and easy with special MiTek 30 x 2.8 galvanised reinforced head nails.
 - Uniform strength – assured performance.
 - Side by side splicing for easy layout and fixing.
 - Positive end fixing – wrap around at apex, splice and frame.
- (Clouts should not be used in fixing SpeedBrace.)

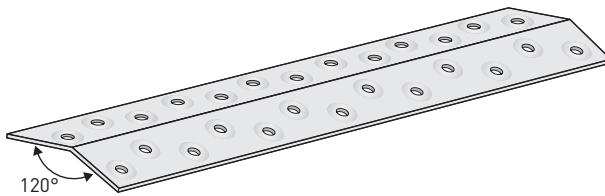

RT051

BOTTOM CHORD BRACING

When plasterboard ceilings are fixed direct to the bottom chords of trusses or via battens in accordance with AS 1684, the horizontal wind load on the roof and walls of a house is normally transferred to the bracing walls through the diaphragm action of the plasterboard ceiling. This structural ceiling diaphragm also provides lateral restraint to the truss bottom chords of the trusses.

If there is no ceiling attached to the bottom chord, or if the ceiling is suspended or fixed using furring channels that are clipped to the bottom chord, then an alternative bottom chord bracing system is required to provide truss stability and building stability.

Where plasterboard is not fixed direct or via battens then:

- Truss stability is achieved by using bottom chord binders and diagonal bracing on the bottom chord similar to roof bracing. The bottom chord binders should be spaced in accordance with the truss design. The ends of both bottom chord binders and diagonal bracing are to be anchored to a rigid building element.
- A structural engineer should be consulted for specific design of a bottom chord bracing system which is suitable for the particular requirements of the building.

TOP CHORD BRACING

The bracing layout is related to the span and shape of the roof.

RT052

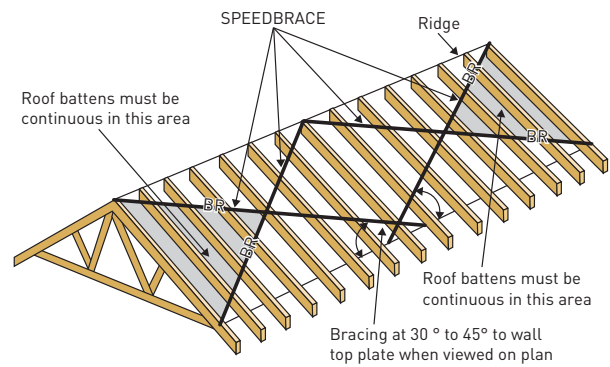

LEGEND

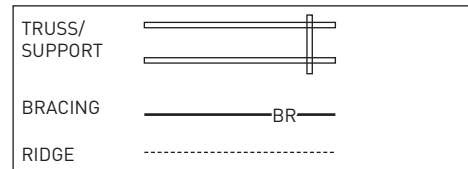

ROOF SPANS LESS THAN 8000 MM

The forces in a roof of less than 8000 mm span are relatively low and may be restrained by the use of a single SpeedBrace in a 'V' configuration. The angle of SpeedBrace to wall frame should be between 30° and 45°, and each truss should be crossed with at least two braces.

For roof lengths less than half span (h) use detail for Very Short Roofs below.

- Very Short Roof** – where the roof length "L" is 1 to 1½ times the half span "h" of the roof truss.

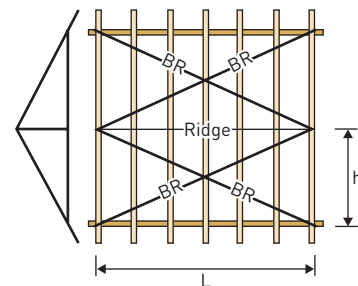

RT053-a

- Short Roof** – where the roof length "L" is 1½ to 3½ times the half span "h" of the roof truss.

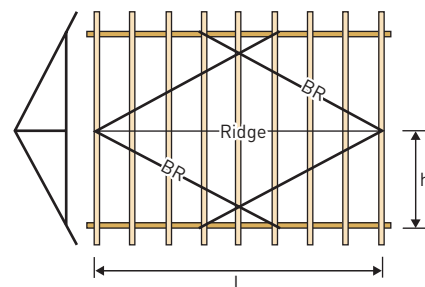

RT053-b

- Long Roof** – where the roof length "L" is 3½ to 4 times the half span "h" of the roof truss.

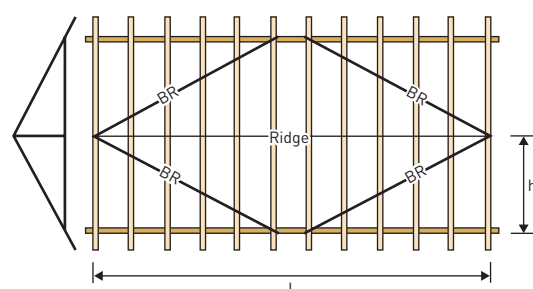

RT053-c

4. Very Long Roof – where the roof length “L” is more than 4 times the half span “h” of the roof truss.

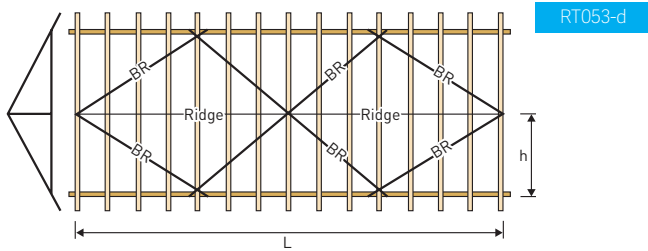

ROOF SPANS 8000 MM TO 13000 MM

The increase in span increases the forces to be restrained requiring the use of SpeedBrace in an “X” configuration. The angle of the SpeedBrace to the frame should be between 30° and 45°. Use a single or double SpeedBrace with maximum overall truss length not exceeding values in Table 4.

Roof Pitch	Wind Classification		
	N3, C1	N4, C2	C3
Single Brace			
< 15°	13.0	13.0	12.0
15° to 20°	13.0	13.0	11.0
21° to 30°	12.5	10.5	8.5
31° to 35°	11.5	9.5	Not Suitable
36° to 45°	9.5	8.0	Not Suitable
Double Brace			
up to 45°	13.0	13.0	13.0

Each truss should be crossed with at least four braces and bracing bays should extend from the end trusses of the building unless noted otherwise.

RT054-a

1. Very Short Roofs. Where the roof length “L” is very short compared to the half span “h” of the roof trusses and would result in a brace angle greater than 45°, a diagonal bracing arrangement is required each side of the ridge line as given below. Bracing bays should be spaced across roof such that the brace angle is always between 30° and 45°.

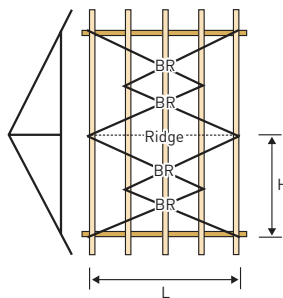

RT054-b

2. Short Roofs. Where the roof length “L” is of length to give a brace angle between 30° and 45° then only one bay of bracing is required each side of the ridge line as shown.

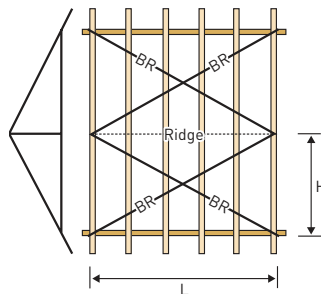

3. Long Roofs. Where the roof length “L” is long compared to the half span “h” of the roof trusses and would result in a brace angle less than 30°, two or more crossed bracing bays are required each side of the ridge to ensure the brace angle is between 30° and 45° as shown.

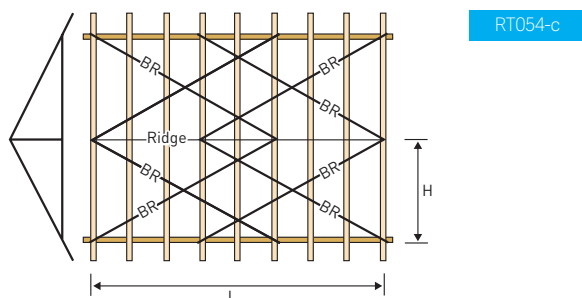

RT054-c

4. Very Long Roofs. As for long roofs, except continue bracing for length of building such that each truss is crossed with at least four braces.

RT054-d

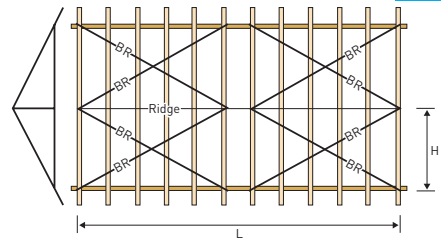

Where the roof requires double SpeedBrace, fix as shown above.

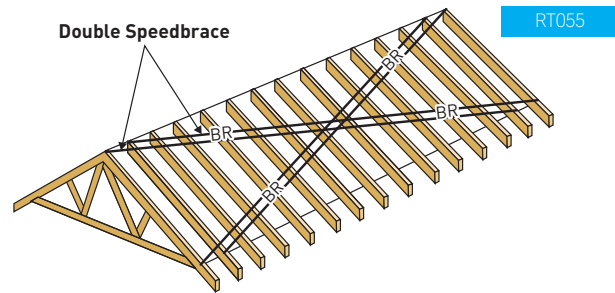

RT055

ROOF SPANS 13000 MM TO 16000 MM

a) For standard trusses, refer to Table 5 to determine whether single or double SpeedBrace can be used in an ‘X’ configuration over the whole roof with an additional braced bay at each end as shown.

Roof Pitch	Wind Classification		
	N3, C1	N4, C2	C3
Single Brace			
< 15°	16.0	15.5	Not Suitable
15° to 20°	16.0	13.0	Not Suitable
Double Brace			
< 15°	16.0	16.0	16.0
15° to 20°	16.0	16.0	15.5
21° to 30°	16.0	14.5	Not Suitable
31° to 35°	16.0	13.5	Not Suitable
36° to 45°	13.5	Not Suitable	Not Suitable

RT056

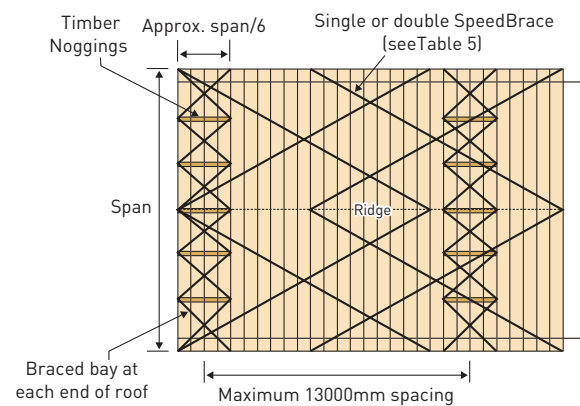

b) For jack trusses or rafters, use single SpeedBrace in an ‘X’ configuration and the angle of SpeedBrace to end wall should be between 30° and 45°.

1. Where the horizontal top chord length (HTL) is less than the truncated girder station (TGS).

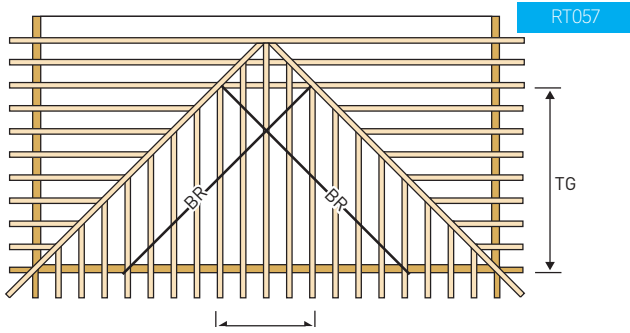

2. Where the horizontal top chord length (HTL) is 1 to 1.5 times the truncated girder station (TGS).

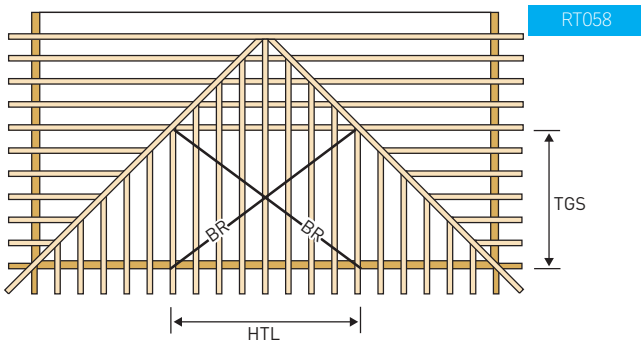

3. Where the horizontal top chord length (HTL) is longer than 1.5 times the truncated girder station (TGS).

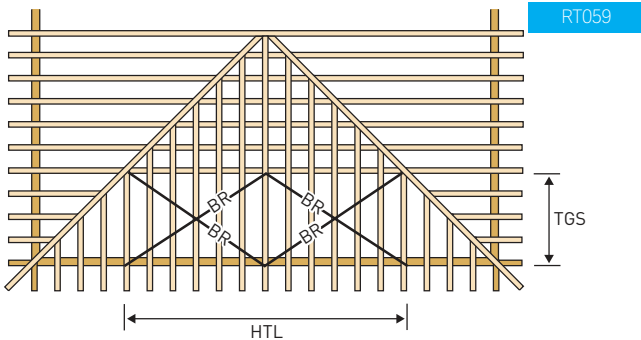

TYPICAL BRACING LAYOUTS

Gable Roof

Select a roof layout such that the angle between the ridge line and the brace is between 30° and 45°. There are eight basic bracing arrangements to consider depending on truss span and building length as given above. Bracing bays should extend from end trusses on the building.

Hip Roof

For roofs on buildings of rectangular plan with trussed hip ends or dutch hip ends, bracing is required between apex of hip ends only. In such cases the roof length "L" is taken as being the distance between the two intersections of hip and ridgeline at each end of the building. One of the recommended bracing layouts for gable roof then can be applied as shown in (a) for roof length "L" ≥ half span "h" of the roof truss, except where roof length "L" of standard truss is less than the half span "h" of the roof truss, in which case bracing should be arranged as shown in (b).

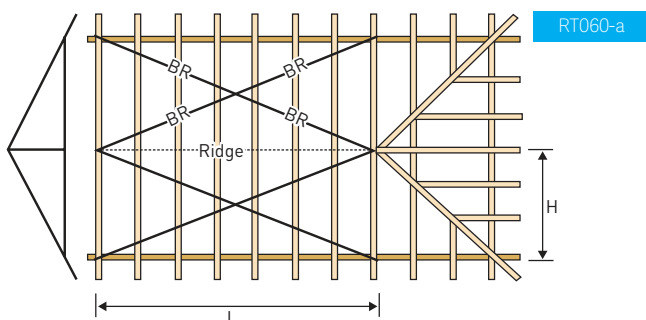

(a) Roof length "L" ≥ half span "h" of the roof truss

RT060-b

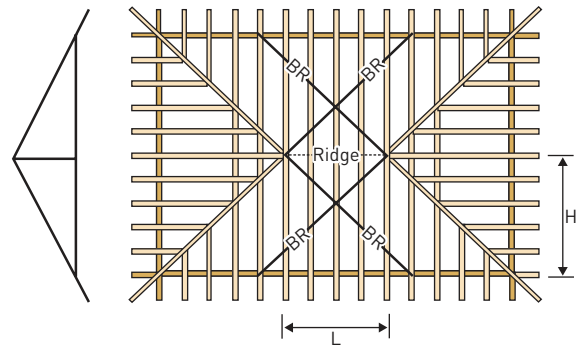

(b) Roof length "L" < half span "h" of the roof truss

Dual Pitched

On dual pitched roofs and cut-off roofs where the ridge line is not central on the building it may be necessary to determine bracing layout from a combination of 1, 2, 3 and 4 above. In such cases each side of the ridge shall be considered as a separate case.

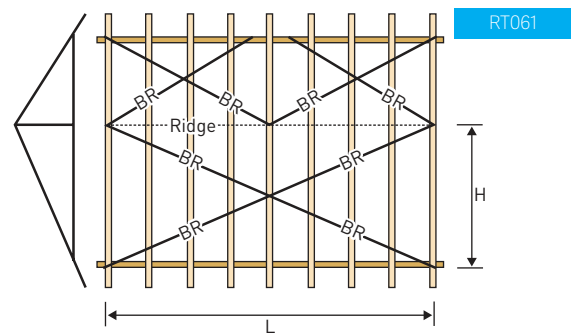

Bell Roof

Bell trusses should be braced as shown. The SpeedBrace should be spliced at bell breaks.

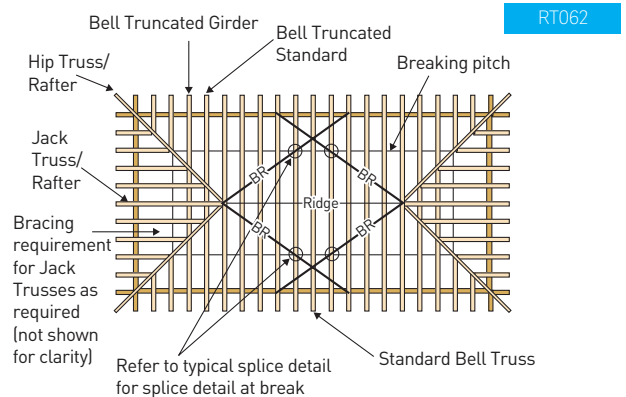

Skillion

Where the roof consists of half trusses, the span of the half truss should be taken as the half span "h" when using the above recommendations, and the apex braced to supporting structure. See section on Treatment of Internal Supports etc.

Note

The previous are typical layouts for bracing. However, for special circumstances, e.g. small spans and complex roof shapes, bracing layout will be supplied.

SPEEDBRACE FIXING DETAILS

1. Always use MiTek 30mm x 2.8mm dia. Galvanised Reinforced Head Nails when fixing SpeedBrace.
2. At each truss, fix SpeedBrace to the top of the top chord with two nails. Select nail holes most central to the timber edge. Flatten bracing while nailing to avoid interference with battens.
3. At end truss fix off the SpeedBrace as shown. A pair of tinsnips will cut the brace. After fixing to top of top chord use your hammer to form a tight bend and fix to face of top chord with three nails.

TYPICAL END FIXING DETAILS

On dual pitched roofs and cut-off roofs where the ridge line is not central on the building it may be necessary to determine bracing layout from a combination of 1, 2, 3 and 4 above. In such cases each side of the ridge shall be considered as a separate case.

RT063

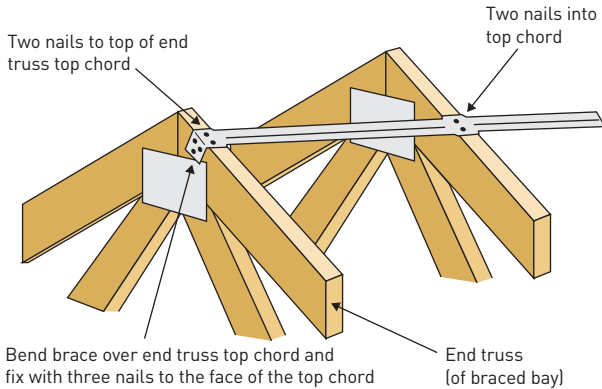

4. To splice SpeedBrace, overlap or wrap around over one truss and fix with three nails. Splice to be located at least 2500mm from heel end fixing, measured along brace.

TYPICAL SPLICE DETAIL (OVERLAP SPLICE)

TYPICAL SPLICE DETAIL (WRAP-AROUND SPLICE)

RT064

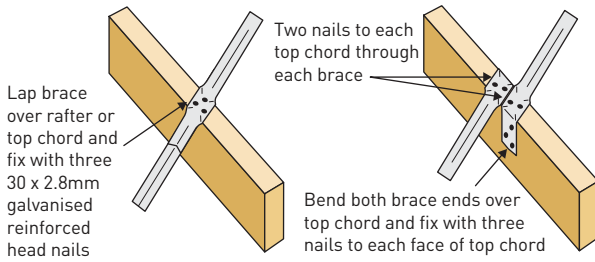

5. At the heel, SpeedBrace should be fixed in one of the following ways: The simplest method, where roof geometry permits is to fix directly to the wall top plate as shown below. The brace must be kept straight between the last braced truss and wall top plate. Also the angle between the brace and the wall top plate must not exceed 45°, i.e. 1:1 slope.

Heel End Fixing Details

RT065

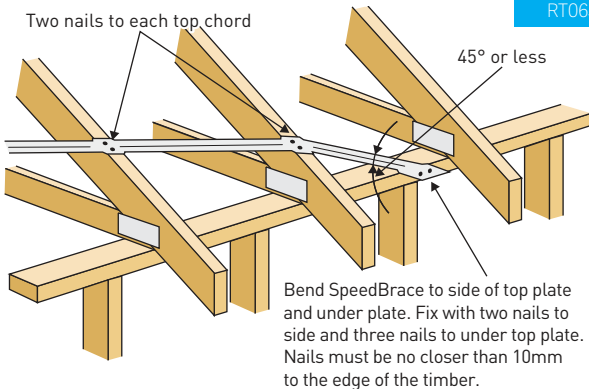

CAUTION: The SpeedBrace must be positively fixed to the top plate otherwise the bracing will be ineffective.

An alternative method can be used where it is desired to extend the brace to the last truss or where the angles do not permit ready fixing to the top plate. The last two trusses should be fixed to the wall top plate with a minimum of two Trip-L-Grips to each truss, and timber block between trusses as shown.

Alternative Heel End Fixing Detail

RT066

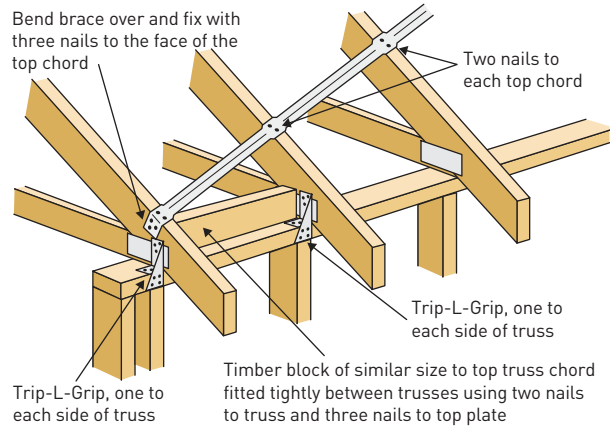

Where the standard trusses are supported by a girder truss or a beam rather than a wall top plate, fix SpeedBrace at truss heel as shown following.

Heel End Fixing at Girder or Beam

RT067

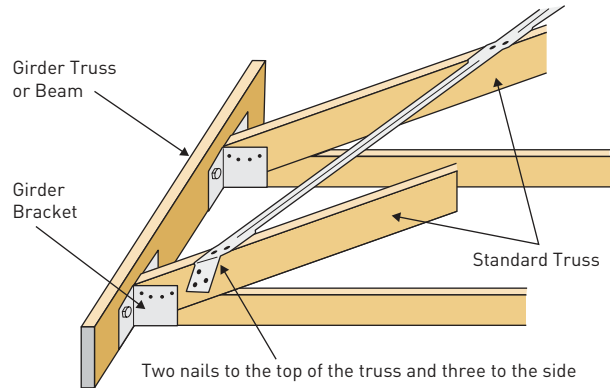

TREATMENT AT CANTILEVERS

The force in the top chord bracing must be carried through to the wall plate by diagonal bracing from the top chord to wall plate, as shown below.

RT068

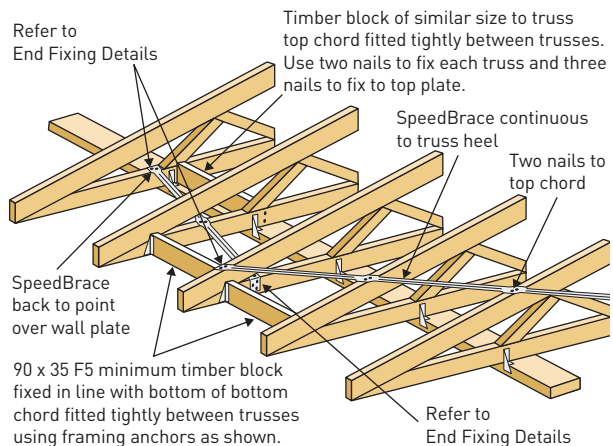

TREATMENT AT CUT-OFF OR HALF TRUSSES

In addition to top chord bracing, cut-off and half trusses require bracing from top chord to top plate at end nearest apex. Apply one bay of diagonal bracing at each end of the run of trusses and intermediate bays at 10m centres for long runs of trusses.

RT069

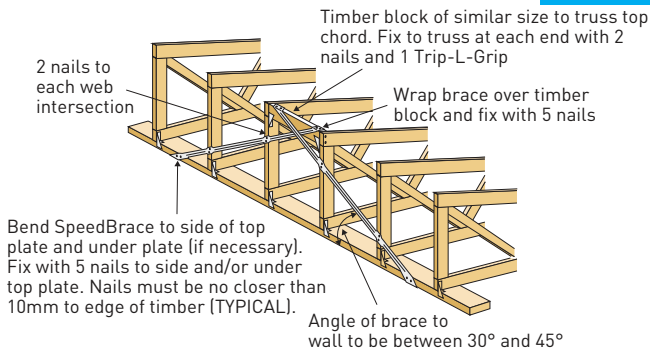

End Bracing for Cut-off and Half Trusses

RT070

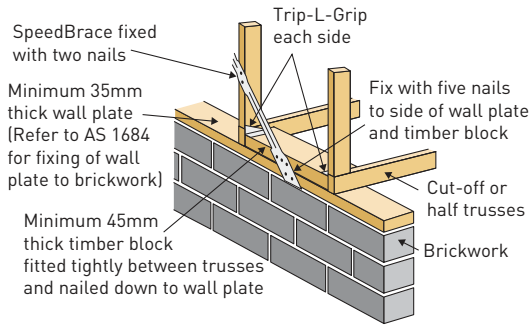

TREATMENT AT BOOMERANG / VALLEY GIRDER

RT071

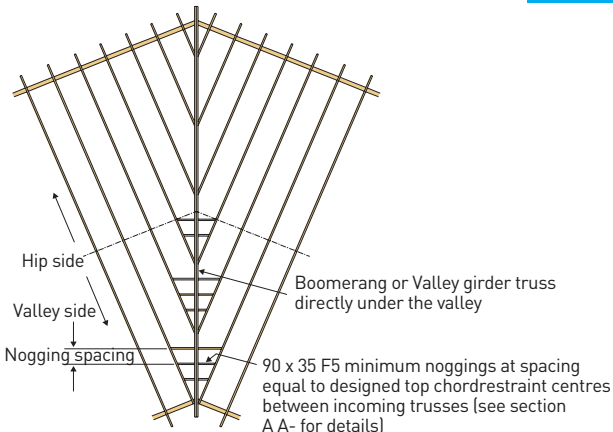

SECTION A-A

RT072

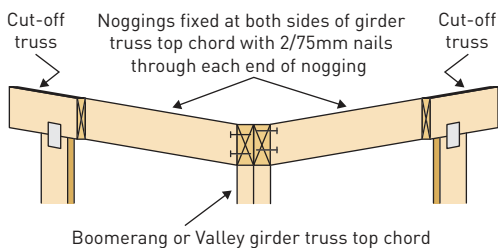

WEB TIES & STIFFENERS

Some truss designs require longitudinal ties, stiffeners or other supplementary members to be applied to webs. Where longitudinal ties are used, they should be 70 x 35 (F5) or as specified by the truss fabricator. Where longitudinal ties are used, they should be continuous and fixed to web of each truss at mid-height with 2 x 3.75 dia. nails and braced back to truss with one bay of crossed SpeedBrace at each end and intermediate bay at 10m centres fixed as shown below. Ties may be spliced by lapping over 2 adjacent trusses.

Web stiffeners may be specified in lieu of web ties where it is difficult to fit web ties because of the small number of trusses or the varying position of the webs. eg. Truncated trusses and Hip trusses.

Web stiffeners may be timber sections fitted on-site or steel Eliminator stiffeners fixed during manufacture. Where timber stiffeners are used these should be the size and grade specified by the truss designer and should be continuous for the full length of the web. Timber stiffeners are to be fixed as below.

Longitudinal Ties

RT073-a

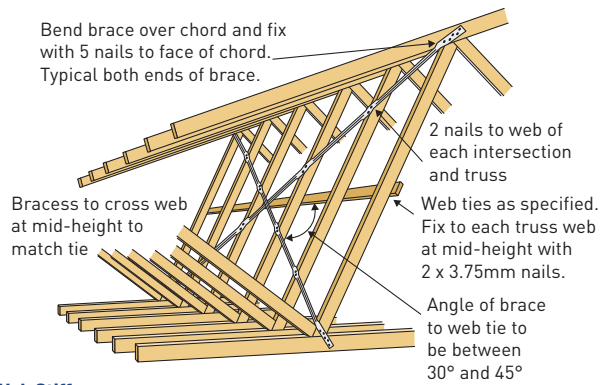

Web Stiffeners

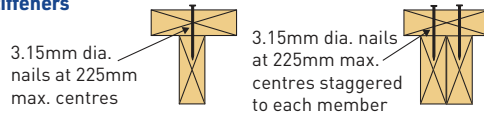

RT073-b

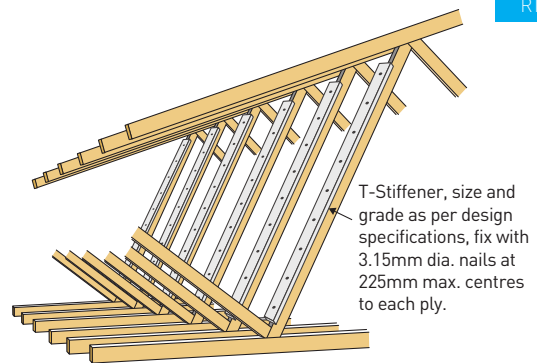

TrussSpacer for Web Tie

RT074

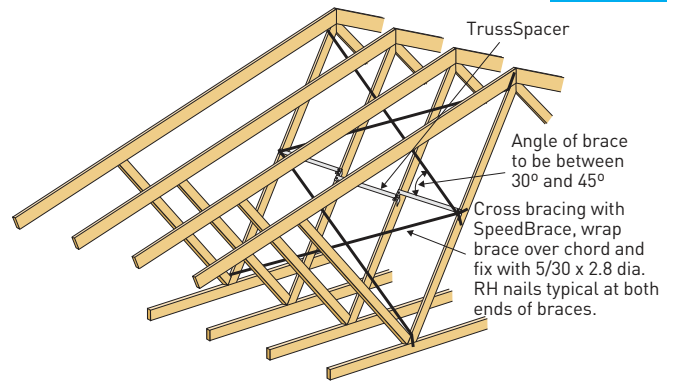

The TrussSpacer can also be used as permanent lateral bracing for webs in standard roof trusses for domestic constructions. The TrussSpacer can be used as a web tie where truss designs require bracing to be applied to webs for the following conditions.

Roof materials:	Sheet or tile roof
Ceiling material:	13mm plasterboard, battened
Spacing:	600 and 900mm
Pitch:	45° max.
Span:	16m
Wind Classification:	Up to C2

HOLD-DOWN DETAILS FOR TRUSSES

CYCLONIC & NON-CYCLONIC

The following details should be used as a guide only as hold down requirements will vary depending on the type of supporting structure. The method of hold down is the responsibility of the builder.

For a more accurate assessment of hold down requirements on specific jobs, refer to truss design outputs.

When tie-downs are attached to frames incorporating single sided stud

straps such as StudStrap and WallStrap, the tie-down bracket should connect to the same side of the frame as the strap.

Details for fixing wall plates to foundations are to be provided by others. The supporting structure must also be designed by others to resist all vertical and horizontal loadings.

TRUSSGRIP (TRG)

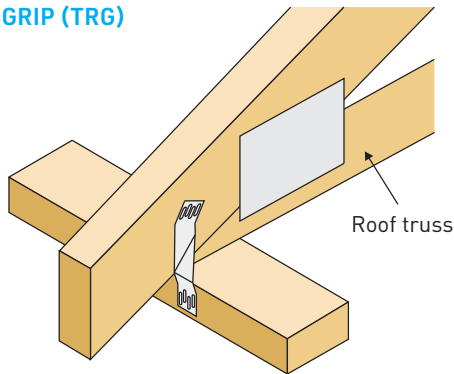

RT075

UNIVERSAL TRIP-L-GRIP (TGU & TGUSS)

Product and fastener are available in galvanised and stainless steel
Top Plate Fixing.

Top Plate Fixing

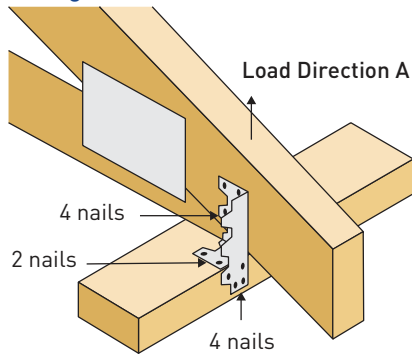

RT076

TRIP-L-GRIP (TGL/TGR & TGLSS/TGRSS)

Product and fastener are available in galvanised and stainless steel

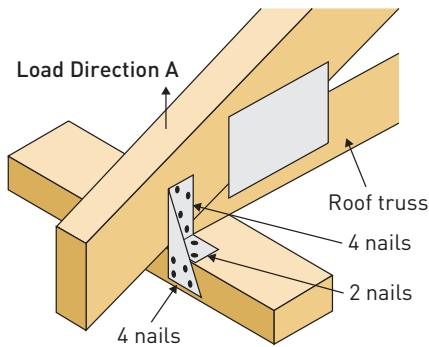

RT077

TRUSSLOK (TL150)

Fixing to Truss between Studs

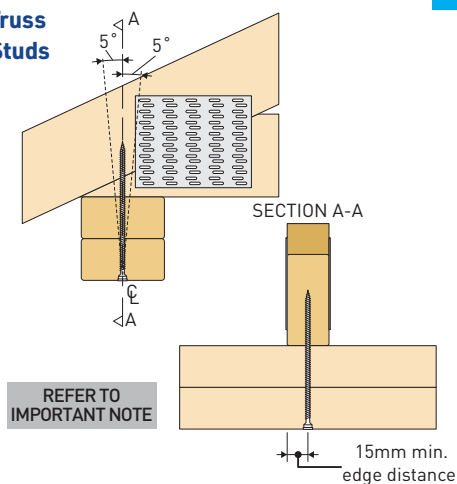

RT077-a

Fixing to Truss Above Stud

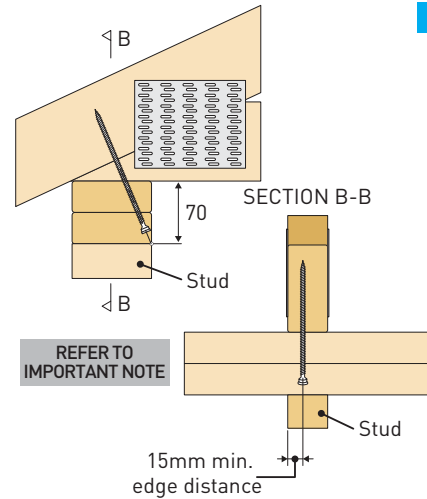

RT077-b

Important Note

Ensure there is no screw point protruding the truss chord face to achieve full design capacity.

RT077-c

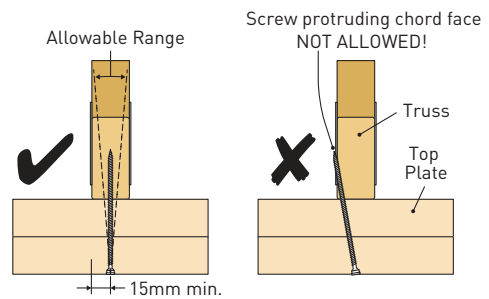

CYCLONETIE CT180 (FACE FIXED)

Double Top Plate

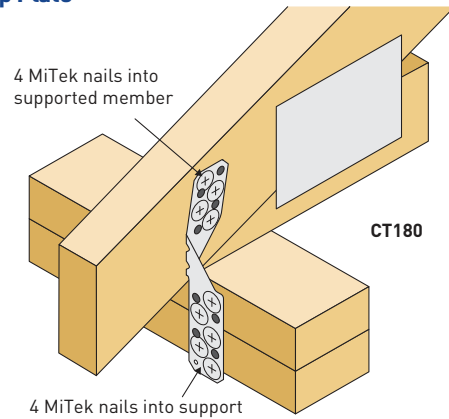

RT078-a

CYCLONETIE CT180 (WRAP UNDER)

Single Top Plate

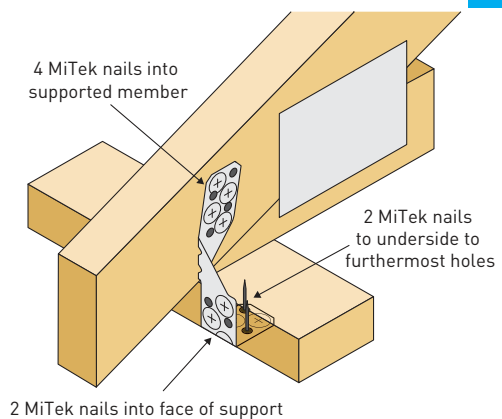

RT078-b

CYCLONETIE CT180 FIXING WITH SCREWS

1. Substitute 1 MSA1430 screw for every 2 nails.
2. Fix screws into pre-punched holes, diagonally across each other.
3. In single top plates, wrap CT180 under, and fix 1 screw to side, and 1 screw under to furthestmost holes.

CYCLONETIE CT400 (FACE FIXED ONLY)

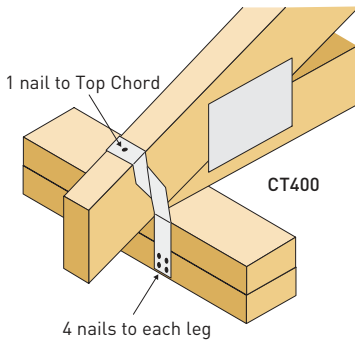

RT079

CYCLONETIE CT600 & CT600SS/CT900 (FACE FIXED)

CT600 and fastener are available in galvanised and stainless steel

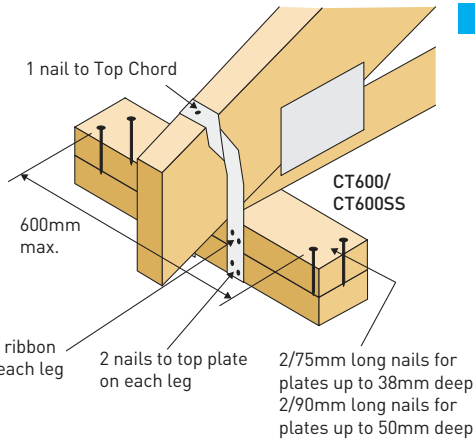

RT080

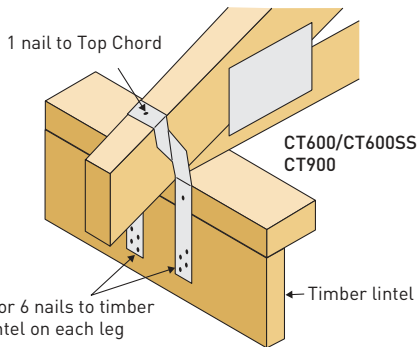

RT081

CYCLONETIE CT600 & CT600SS/CT900 (WRAP UNDER)

CT600 and fastener are available in galvanised and stainless steel

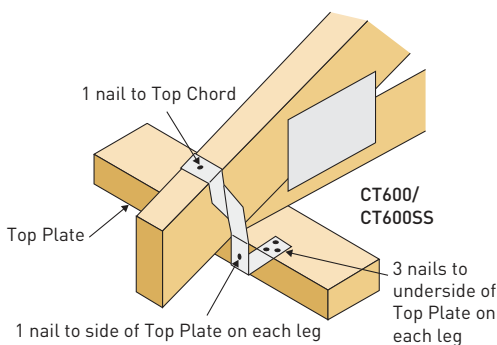

RT082

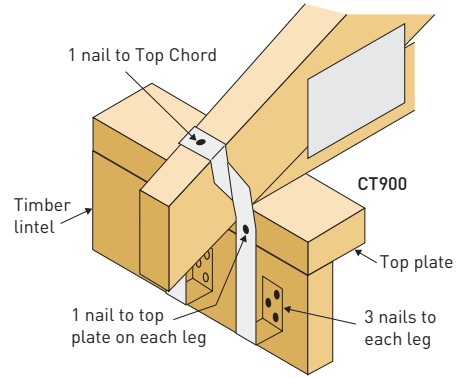

RT083

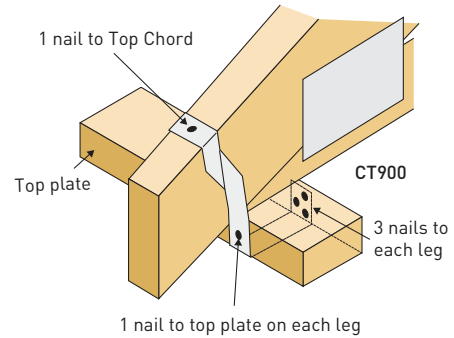

RT084

2 CYCLONETIES CT600 & CT600SS/CT900 (WRAP UNDER)

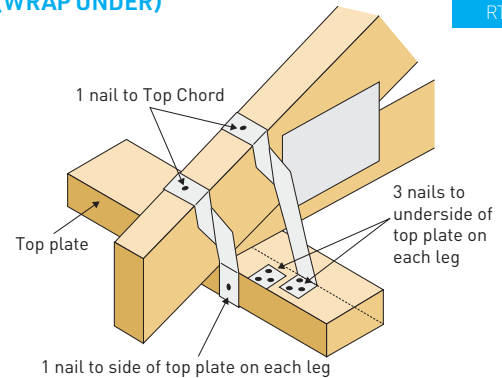

RT085

Maximum Top Chord size	Top Plate size	Maximum Pitch (degree)
140 x 35	90 x 35	26.0
140 x 45	90 x 35	22.5
140 x 35	90 x 45	19.0
140 x 45	90 x 45	16.0
90 x 35	2 / 90 x 35	37.5
90 x 45	2 / 90 x 35	33.5
90 x 35	2 / 90 x 45	22.5
90 x 45	2 / 90 x 45	19.0

CYCLONETIE CT1200 (FACE FIXED)

RT086

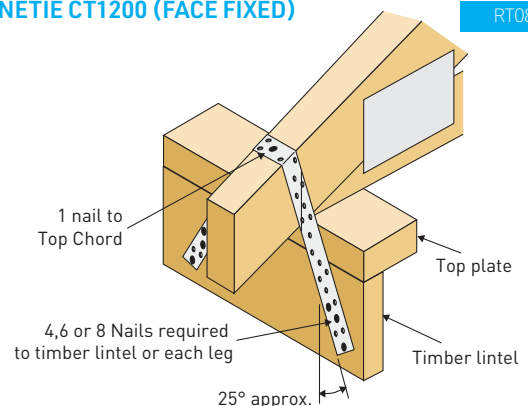

CYCLONETIE CT1200 (WRAP UNDER)

RT087

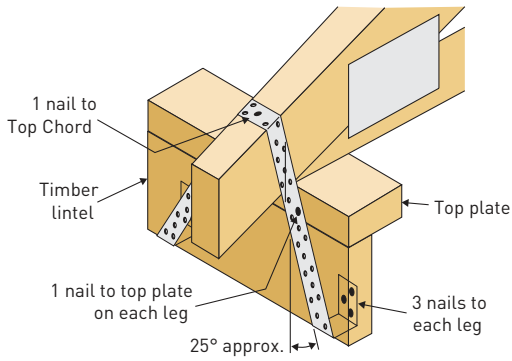

RT088

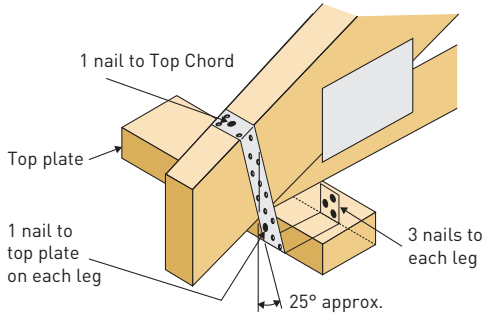

RT090-b

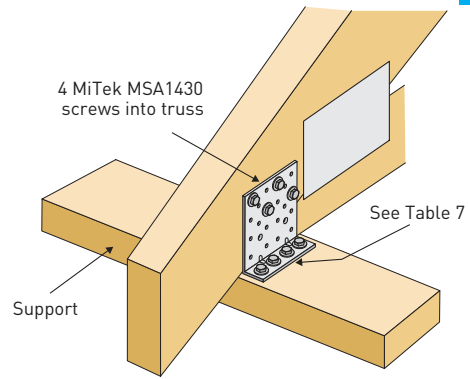

Minimum support width (mm)	Number of screws into support
90	4
70	3
45	2

CYCLONETIE CT1200 (RAFTER/TRUSS TO STUD)

RT089

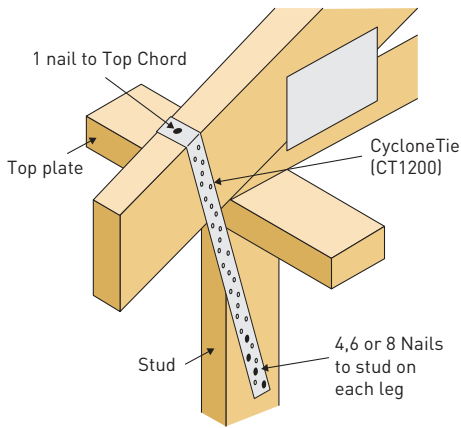

RT090-c

CONCRETE FIXING CLEAT CF1

TYPE A

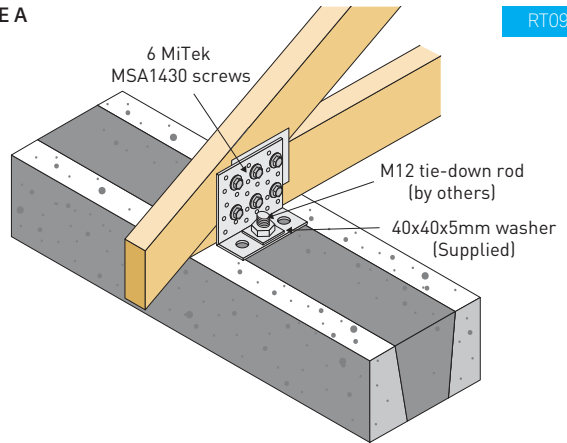

RT090-d

TYPE B

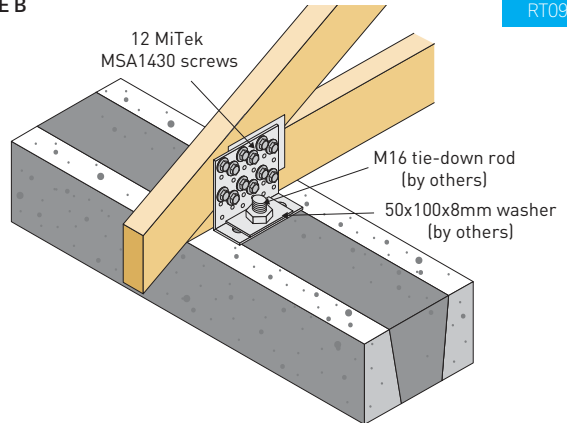

CONCEALED PURLIN CLEAT (CPC40 & SSCPC40)

Product and fastener are available in galvanised and stainless steel. Use longer screws if fixing down to double top plates or supporting beams for higher uplift capacity.

RT090-a

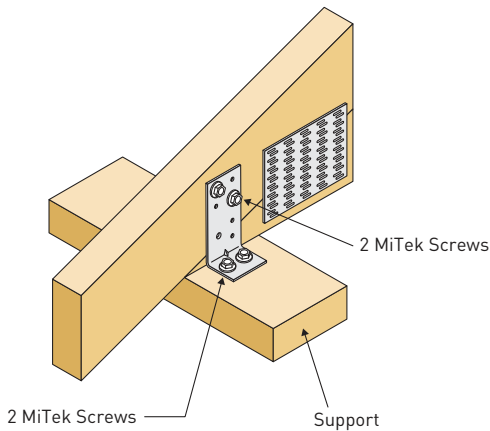

RT091-a

BLOCKFAST (BF)

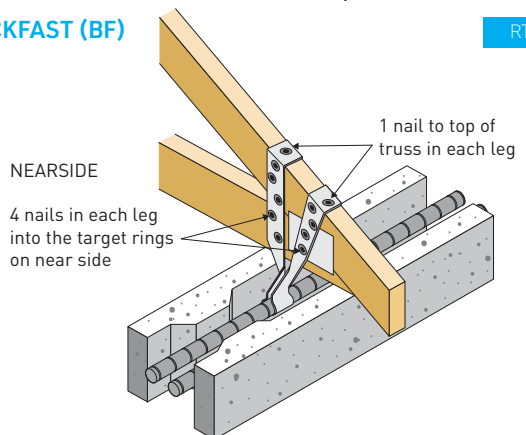

CONCEALED PURLIN CLEAT (CPC80 & SSCPC80)

Product and fastener are available in galvanised and stainless steel. Use longer screws if fixing down to double top plates or supporting beams for higher uplift capacity. The required number of screws depends on the width of support as shown in the Table 7.

FAR SIDE

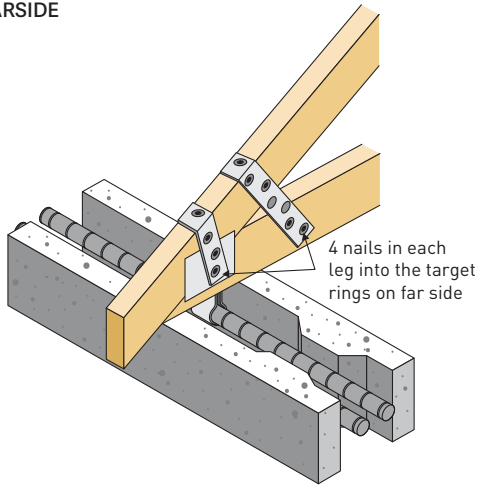

RT091-b

TYPICAL SIDE ELEVATION

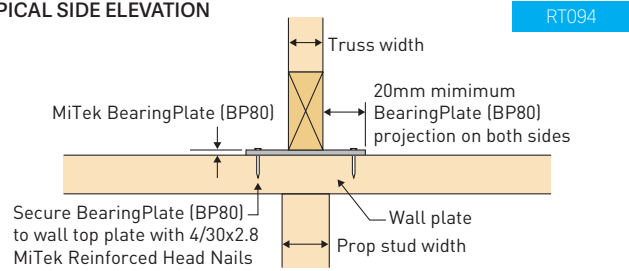

RT094

Note

1. Nails are to be FAP 32 V5 hardened electro-galvanised pneumatically driven.
2. Safety gear must be worn when nailing.
3. See product data sheet for other fixing variations.

BEARINGPLATE (BP80)

The BearingPlate has been developed to improve the crushing resistance of wall plates under heavily loaded trusses. The positioning of a ConnectorPlate onto the bottom chord of the truss above the BearingPlate as shown in these specifications, will also improve the crushing resistance of the bottom chord to match the wall plate.

FIXING INSTRUCTIONS FOR BEARINGPLATE

Position the BearingPlate centrally along the top of the wall plate and such that it projects at least 20mm on either side of the supported truss. Fix with four 30 x 2.8mm MiTek Reinforced Head Nails. The bottom chord of the truss is to be reinforced with a ConnectorPlate located not more than 6mm above the BearingPlate, and projects at least 10mm beyond the BearingPlate, as illustrated.

In addition to the BearingPlate, a tie down connection is required to resist uplift. This connection should not be less than two Trip-L-Grips.

GIRDER BRACKETS

Girder Brackets have been developed to support standard trusses on the bottom chord of girder trusses or beams, and may also be used to connect beams to beams. The brackets have been designed and tested to ensure that the load of the standard truss is transferred to the girder truss or beam without inducing rotation in the supporting member.

Determination of Bracket Type

A range of Girder Brackets are available. The type of bracket required for your project will depend on the loads which it is required to carry. The selection of bracket type should be done in conjunction with your MiTek fabricator or a Structural Engineer.

FASTFIT MKIII GIRDER BRACKET - SCREWS (GB340, GB350)

FastFit MKIII Girder Bracket can be installed with MiTek self tapping screws for speedy installation.

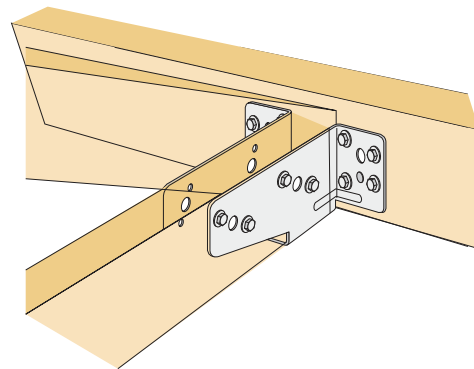

RT095

FASTFIT MKIII GIRDER BRACKET - BOLTS (GB340, GB350)

FastFit MKIII Girder Bracket can also be installed with M12 bolts for speedy installation.

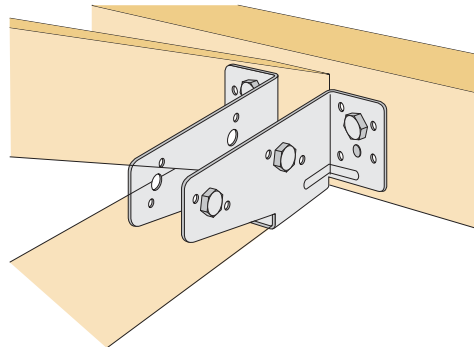

RT096

HEEL SUPPORT

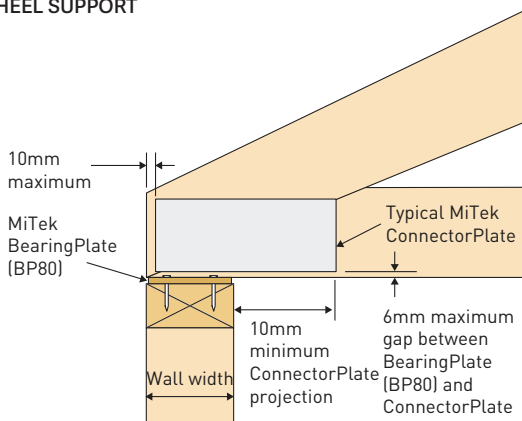

RT092

INTERNAL SUPPORT

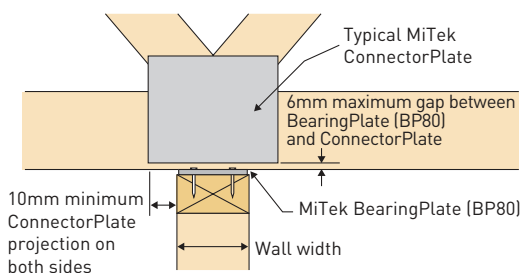

RT093

FASTFIT MKIII CYCLONIC GIRDER BRACKET (GB340, GB350 CYCLONIC)

FastFit MKIII Girder Bracket can be used in cyclonic wind areas to restrain large uplift if additional washers and screws are used as specified.

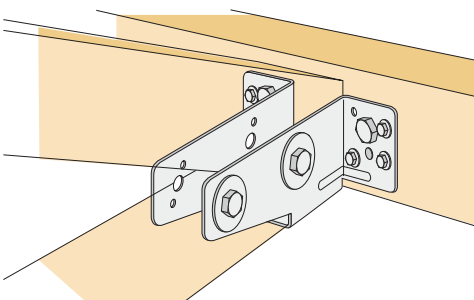

RT097

FASTFIT MKIV GIRDER BRACKET - SCREWS (GB440, GB475)

FastFit MKIV Girder Bracket provides more economical connection than heavy steel brackets with similar design capacities.

RT098

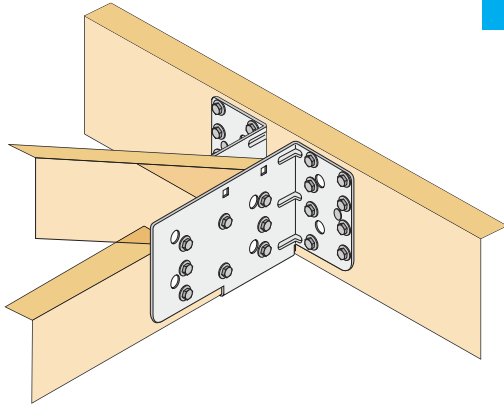

FASTFIT MKIV GIRDER BRACKET - BOLTS (GB440, GB475)

FastFit MKIV Girder Bracket can also be installed with M12 bolts.

RT099

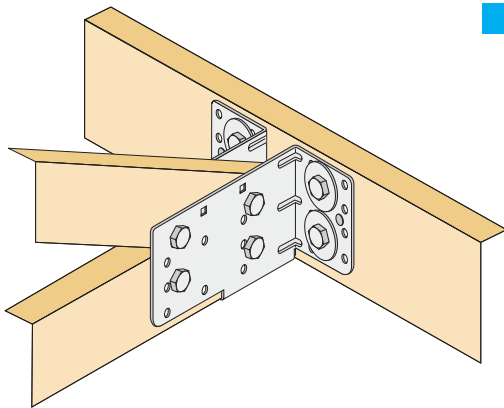

HIP GIRDER BRACKET (HGB35)

A Hip Girder Bracket HGB35 can be installed on one or both sides of FastFit Girder Brackets GB340, GB440 and GB475 using screw holes which are aligned with the screw holes in the FastFit Girder Bracket.

RT100

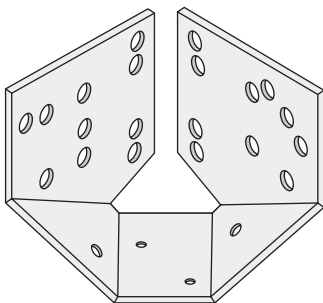

GENERAL FIXING INSTRUCTIONS

1. Locate bracket on girder truss bottom chord and hold in position by nailing through locating holes. If bracket has anti-rotation tab, fix nails to underside of girder.
2. If bolts are used to fix bracket, drill through 12mm pre-punched holes into girder. Fix bracket with bolts and washers. No additional fasteners are required for multiple ply girders beyond nominal fixing.
3. If screws are used in FastFit MkIII and MkIV Girder Bracket, drive screws through 7mm pre-punched holes into girder. Use 30mm screws in single ply and 65mm screws in double 35mm ply girder. With triple 35mm ply girder, use 65mm screws in bracket and fix 3 additional 65mm screws in back of girder truss behind bracket. Alternatively, use 100mm No. 14 Type 17 hex head screws in bracket. With multiple 50mm ply girder, use bolts or longer screws.
4. Install supported truss on bracket and position it hard against girder.
5. Fix supported truss to bracket according to diagram for type of Girder Bracket.
6. All Fasteners (bolts, screws and nails) must be tightly secured before trusses are loaded.

NOMINAL MULTIPLE PLY TRUSS FIXING

Over and above the additional fixing for different Girder Brackets in multiple ply girders, the following nominal fixing must also be installed.

DOUBLE TRUSS

Fasten all chords and webs together with 3.05 x 75mm glue coated or ring shank nails (at angle), or No. 14 x 65mm screws (35mm timber) or 75mm screws (50mm timber) at 300 centres, staggered on one side only.

TRIPLE TRUSS

Fasten each outer ply to middle ply using details for double truss. In addition, join trusses at each panel joint with one M12 bolt.

General Notes

Apply to all Girder Bracket types

1. Holes to be drilled to suit M12 bolts. Do not drill oversized holes. Use hexagonal head bolts. **DO NOT USE REDUCED SHANK OR CUP HEAD BOLTS.**
2. Use 50 x 50 x 3 mm square or 56 mm diameter x 3 mm round washer for M12 bolts.
3. Nails, where specified, to be MiTek 30 x 2.8mm diameter hot dipped galvanised reinforced head nails.
4. Minimum Girder Truss bottom chords apply to each type of Girder Bracket. Refer Installation Instruction drawings.
5. Where ceiling is to be fixed directly to bottom chord, notching of the heel of supported trusses is recommended to obtain a better ceiling line, when using MkII and FastFit short tab Girder Brackets
6. Screws, where specified, to be MiTek MSA1430 or MSA1465 anti-split self-drilling HD galvaized screws. **DO NOT OVERTIGHTEN SCREWS.** Use suitable power screw driver (not power drill) with torque clutch properly adjusted, or depth limiting driver.
7. When driving screws into denser hardwood, screws should be driven in a single action. Do not partly drive screws and attempt to re-start. Remove partly driven screws and start process again.

FASTFIT MKIII - BOLT FITTING

RT101-a

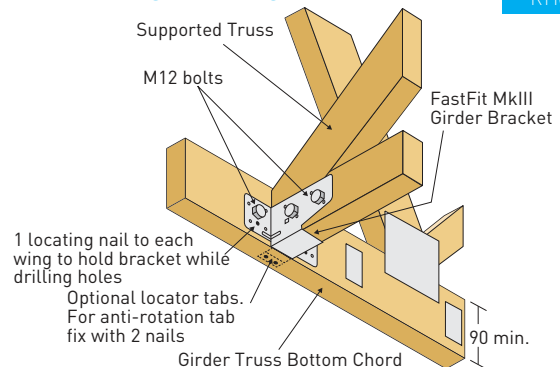

RT101-b

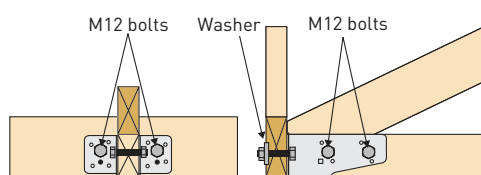

FASTFIT MKIII - SCREW FITTING

RT102-a

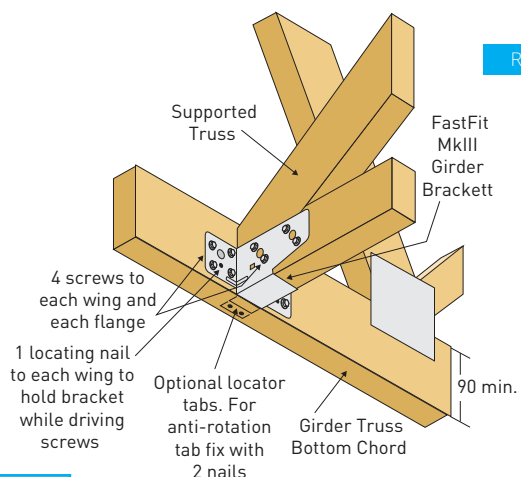

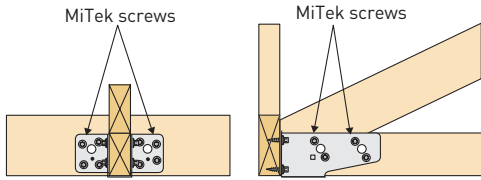

RT102-b

FastFit MKIV - Bolt Fixing

Fix FastFit MkIV Girder Bracket with 4 M12 bolts to the girder truss bottom chord and 4 M12 bolts to the supported truss. Use washers on both sides of girder truss bottom chord.

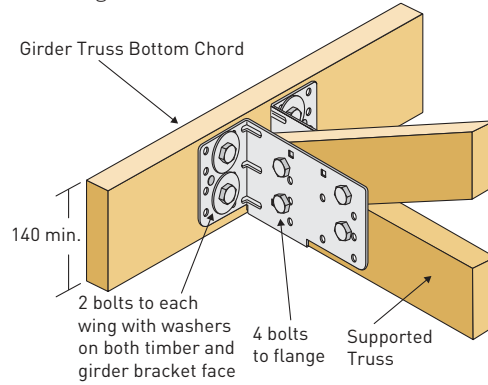

RT106

FOR GIRDER BRACKET MK III IN CYCLONIC AREAS.

Use 3 MiTek screws to each wing in addition to M12 bolts. Washers are also required on both sides of flanges. If length of heel plate is less than 175mm then the supported truss should be either manufactured with GQ4075 Anti Split plates, or alternatively have 3T10 Tylok Plates installed on site. (See diagram).

FASTFIT MKIII CYCLONIC

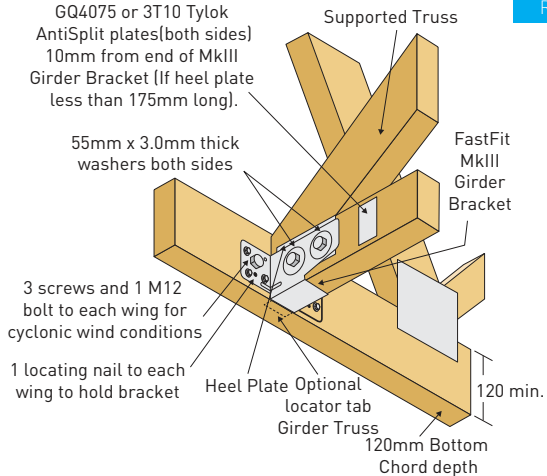

RT103-a

HIP GIRDER BRACKET

1. Locate FastFit Girder Bracket on girder truss bottom chord and hold in position by nailing through small locating holes.
2. Position and align the screw holes of the Hip Girder Bracket HGB35 with the screws holes in the FastFit Girder Bracket.
3. Drive four screws in HGB35 through common holes in FastFit Girder Bracket wing. Drive all remaining screws into wings of FastFit Girder Bracket. Use MSA1430 screws in single ply and MSA1465 screws in double ply 35mm girder. Refer to FastFit Girder Bracket instructions on page 21 for triple 35mm ply girders and multiple ply 50mm girders.

RT107-a

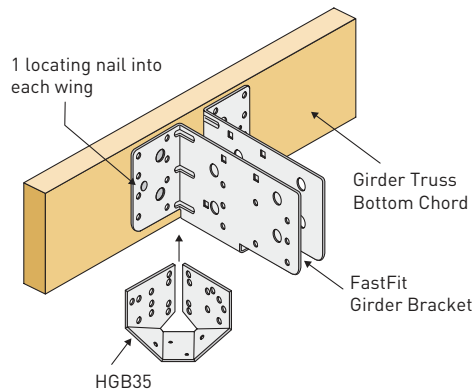

RT103-b

RT107-b

FASTFIT MKIV - SCREW FIXING

For 120mm Girder Truss Bottom Chord

Fix FastFit MkIV Girder Bracket with 12 screws to the girder truss bottom chord and 16 screws in round holes to the supported truss.

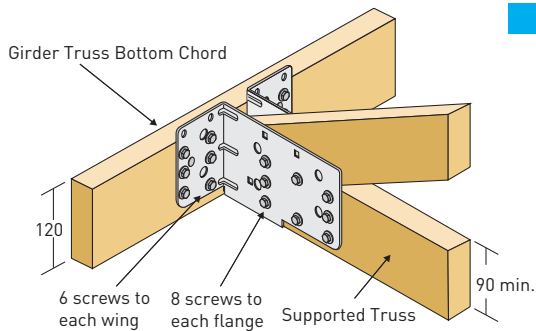

RT104

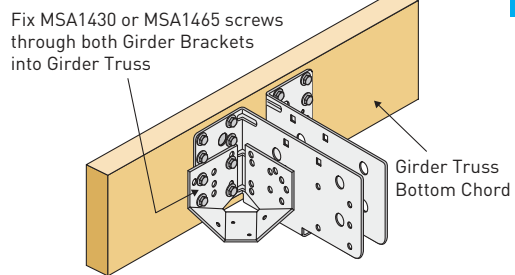

RT107-c

FOR 140MM GIRDER TRUSS BOTTOM CHORD

Fix FastFit MkIV Girder Bracket with 16 screws to the girder truss bottom chord and 16 screws in round holes to the supported truss.

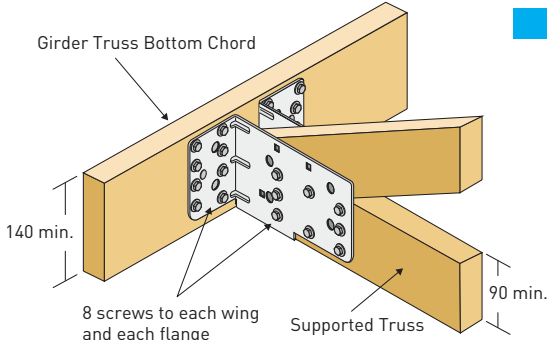

RT105

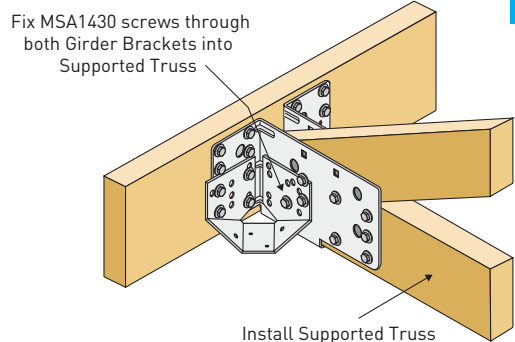

4. Install supported truss on FastFit Girder Bracket and position it hard against the girder truss to ensure all trusses are plumb.
5. Drive 2 MiTek screws through common holes in HGB35 and FastFit Girder Bracket flange and fix the remaining screws into the supported truss.

6. Position hip truss/rafter on HGB35 and optionally secure with 2 nails under.

7. Drive MSA1465 screws through both inclined sides of HGB35 into hip truss/rafter.

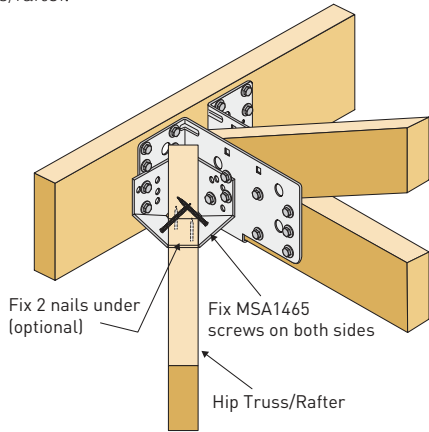

RT107-d

UNIVERSAL GIRDER BRACKETS

MidLoad (GBM) and HiLoad (GBH) Girder Brackets

These Girder Brackets are manufactured with a long cleat to prevent twisting of the bottom chord of the girder truss. The cleat also has a cut away section which avoids the possibility of interference with ceiling linings. The supported truss can also be located on either side of the cleat making the location of the bracket much simpler.

The HiLoad Girder Bracket is suitable for girder truss bottom chords of 130mm and deeper. Whereas, the MidLoad Girder Bracket incorporates M12 bolts, therefore reducing cost and allowing the use of 90mm bottom chords.

GBM

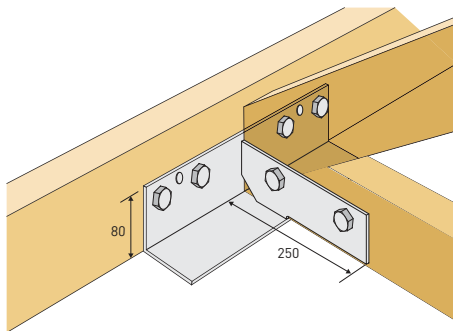

RT108-a

GBH

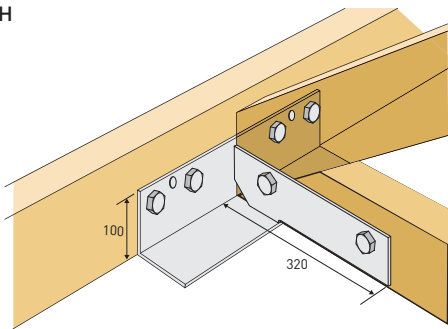

RT108-b

BOOMERANG GIRDER BRACKET

Specifications for Boomerang Girder Bracket are the same as Universal HiLoad Girder Bracket except for cleat angle.

When ordering specify left hand (LH) or right hand (RH) and the angle required. Boomerang Girder Brackets are available with 22.5° or 45° cleats only. For other angles use a wedge as specified in installation instructions.

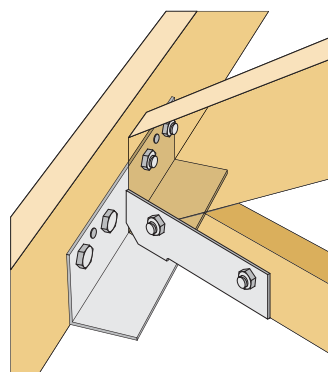

RT109-a

GBBL22
GBBL45

GBBR22
GBBR45

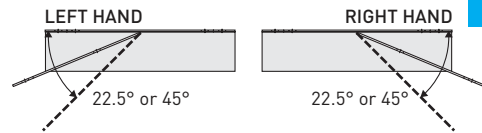

RT109-b

FIXING INSTRUCTIONS FOR HILOAD AND MIDLOAD GIRDER BRACKETS

1. Install the Girder Truss straight and plumb. Apply temporary and/or permanent bracing as required by design.
2. Locate bracket on Girder Truss bottom chord and fix into position by nailing through locating holes.
3. Drill through pre-punched bolt holes into Girder Truss bottom chord. Fix bracket to Girder Truss bottom chord with bolts ensuring correct washers are used to provide bearing against the timber.
4. Position Standard Truss in the bracket so that it is hard against both the cleat and the vertical leg of angle.
5. Fix truss being carried to Girder Bracket by drilling through pre-punched holes in Girder Bracket.
6. Ensure washers are fitted and all bolts are tightened before loading roof.

Notes

1. Holes to be drilled to suit M16 bolts for Girder Bracket HiLoad and M12 bolts for Girder Bracket MidLoad. Do not drill oversized holes and use hexagonal head bolts. DO NOT USE REDUCED SHANK OR CUP HEAD BOLTS.
2. Girder Truss bottom chords to be a minimum of 130mm (nominal) for Girder Bracket HiLoad and 90mm for Girder Bracket MidLoad.
3. Where ceiling is to be fixed directly to bottom chord, notching of the heel of supported trusses is recommended to obtain a better ceiling line.
4. Supported Truss bottom chords to be a minimum of 90mm (nominal) for Girder Bracket HiLoad.

Midload

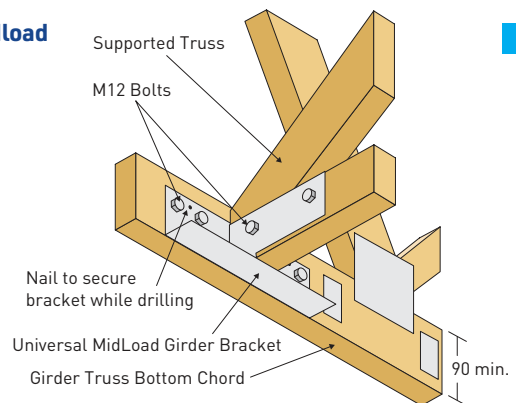

RT110-a

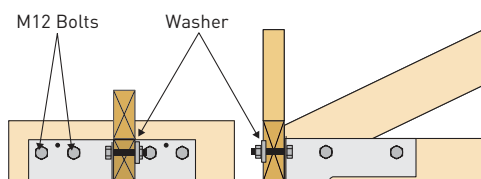

RT110-b

HiLoad

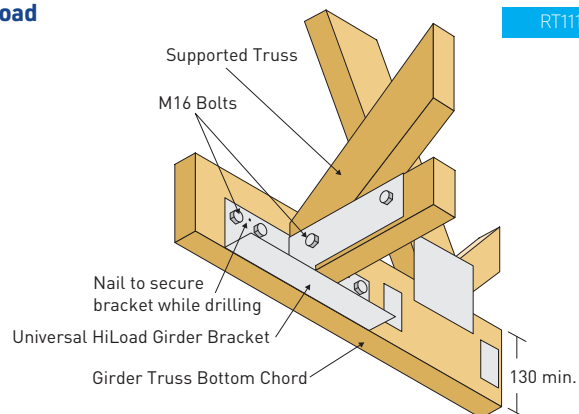

RT111

FIXING INSTRUCTIONS FOR BOOMERANG GIRDER BRACKETS

- 1 Follow steps 1 to 6 as for HiLoad and MidLoad Girder Brackets on previous page.
2. For trusses with intersecting angles that do not correspond to cleat angle, cut suitable dry timber wedges to match angle.
3. Install standard truss and clamp wedges on both sides as shown at right.
4. Drill through pre-punched holes and fit 2/M16 bolts.

Notes

1. Holes to be drilled to suit M16 all thread bolts for Girder Bracket Boomerang. Do not drill oversized holes and use hexagonal head nuts. DO NOT USE REDUCED SHANK OR CUP HEAD BOLTS.
2. Where ceiling is to be fixed directly to bottom chord, notching of the heel of supported trusses is recommended to obtain a better ceiling line.
3. Supported Truss bottom chords to be a minimum of 90 mm (nominal) for Girder Bracket Boomerang.

Boomerang

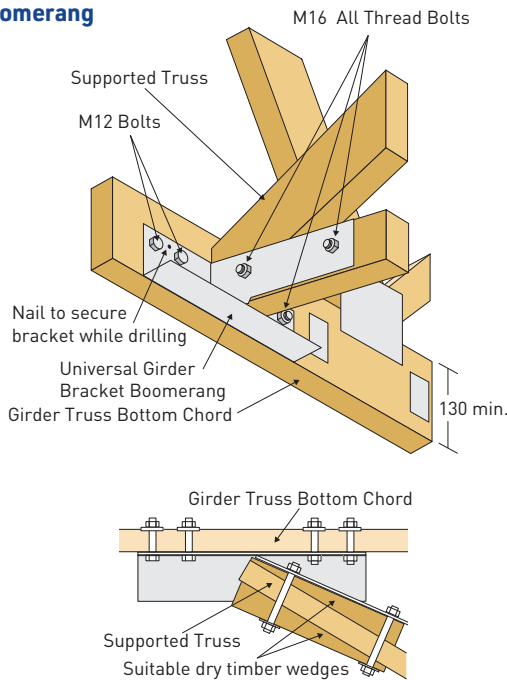

RT112

RT113

HIP HOLD-DOWN WITH CYCLONETIE 1200

CycloneTie 1200 can be used for Hip hold down in conjunction with Mid/HiLoad girder brackets.

Fixing instructions for hip hold down with CycloneTie 1200

1. Secure the incoming girder and locate the hip truss into position. Bend a CycloneTie 1200 over the top chord of the hip truss and move about 200mm along top chord and fix with one nail.

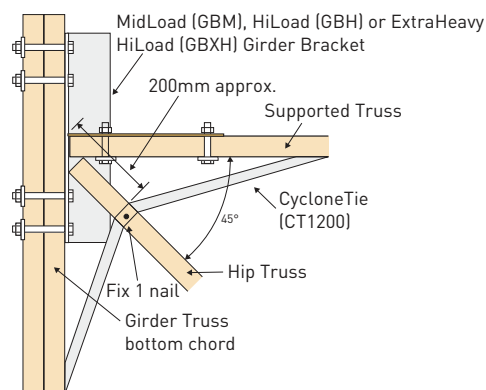

RT114-a

2. Bend one leg under the bottom chord of the incoming girder and the other under the supporting girder. Tap slightly to make a tight bend then wrap them under the chords and fix with 4 nails as shown in diagram below.

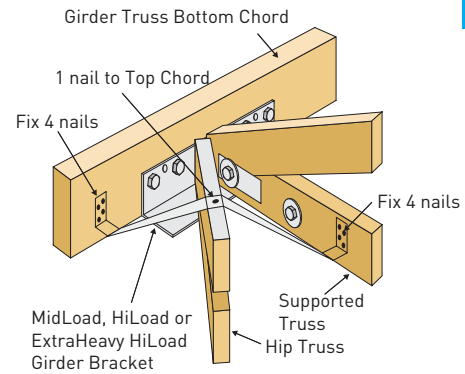

RT114-b

Overhang Strutting

Where rafters or truss overhangs require additional support, the overhang is strutted in accordance with AS 4440 as shown in the following diagrams. Refer to AS 4440 for full details

(a) Truss pitch >18°

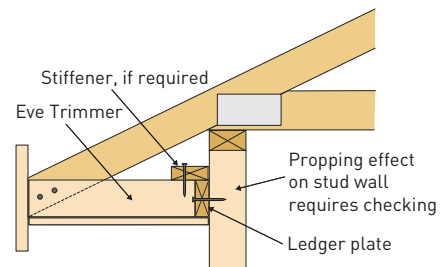

RT115-a

(b) Truss pitch <18°

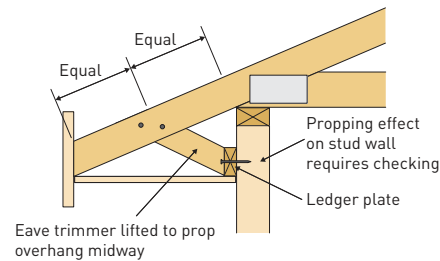

Hip Corner Details

RT116

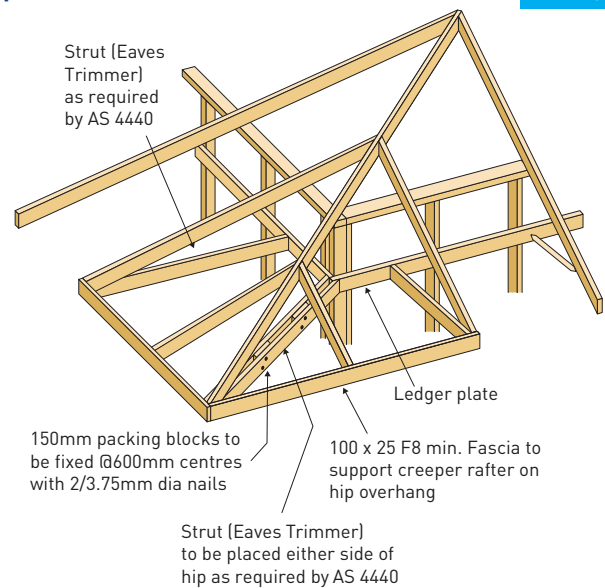

Notes

- The hip corner detail is not suitable for the following situations:
1. Where the hip corners have a cantilevered section of roof on either side of the overhang. Special engineering is required in the case of cantilevered roof.
 2. The standard roof overhang exceeds 900mm.
 3. The truss spacing exceeds 900mm.

GUARDRAIL SYSTEMS

Where guardrails are attached to overhangs, additional overhang stiffeners may be required. The Tables 8 and 9 provide maximum unstiffened overhang distances for top chords supporting guardrail posts. Where stiffeners are required to support guardrail, the maximum overhang distance is the same as the unstiffened top chord which only supports the design roof loading.

These recommendations only apply where:

1. Trusses have been designed and manufactured by authorised MiTek fabricators.
2. Guardrail loads are as specified in AS 1657-1992 'Fixed platforms, walkways, stairways and ladders-Design, construction and installation'.
3. Only one guardrail post is to be fitted to a truss overhang.
4. Maximum spacing of guardrail posts in 2400mm.
5. A guardrail post is not to be fixed to a jack rafter whose total length is less than twice its overhang.
6. Guardrail posts are not fixed to the gable end or raking trusses. All guardrail systems used on gable ends are to restrain guardrail system loads independently of raking truss.
7. Guardrails should be fixed continuously around the corners, such as hip ends of roofs with minimum of two guardrail posts in both directions before the rail is spliced.

Important Note

1. These recommendations are not suitable for supporting fall-arrest systems and devices.
2. Truss modifications in this sheet have been checked for top chord/jack rafter fixed guardrail systems only.
3. No truss members are to be cut or drilled, to enable the fixing of guardrail posts.

TRUSS MODIFICATIONS

A stiffener member is to be fixed to the side of a jack rafter or truss top chord overhang at each point where a guardrail post is located and where the overhang exceeds the value in Table 8 and 9.

The stiffener is to be continuous and extend from the end of the overhang to the first panel point of the truss top chord plus 200mm or to the entire length of a jack rafter. Refer to detail A.

Stiffener is to be the same grade as the overhang and fixed with minimum 65mm long by 2.8mm diameter nails, staggered to one side only as shown in Figure 3. In addition, fix two nails at the truss heel (or support point) and at ends of the stiffener. Where screws are used in lieu of nails, use minimum No. 10 gauge screws at the same spacing and pattern, provided that they penetrate a minimum of 75% into the thickness of the final receiving member.

FIGURE 3. NAIL LAMINATION OF STIFFENER

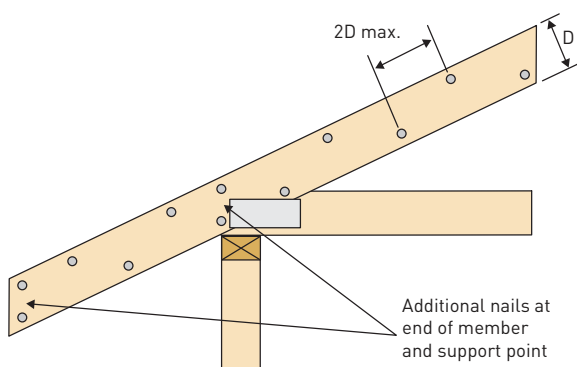

RT117

Detail A. (N.T.S.)

RT118-a

a) Standard truss

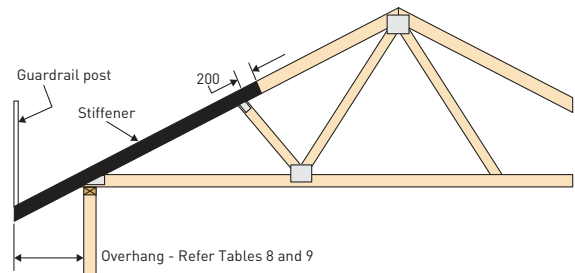

b) Truncated truss

RT118-b

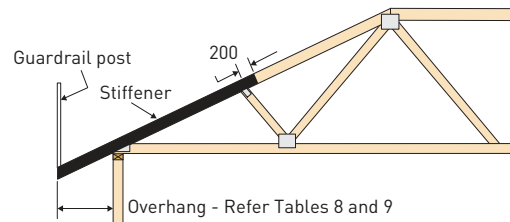

c) Jack rafter

RT118-c

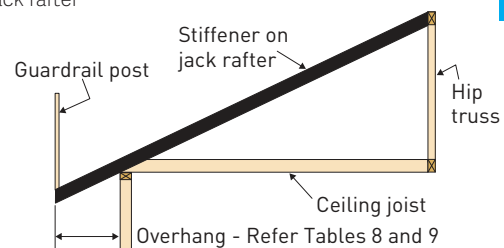

Table 8 - Stiffener Fixing Requirements - Unseasoned timbers				
Size	Grade			
	F8	F11	F14	F17
Maximum overhang with no stiffener required to support guardrail post				
Jack rafters/trusses with sheet roof @ 900 mm max. spacing. Wind Class. N4 & C2				
75 x 38	N	N	N	800
75 x 50	N	800	850	950
100 x 38	650	900	1000	1100
100 x 50	900	1050	1150	1250
Jack rafters/trusses with sheet roof @ 1200 mm max. spacing. Wind Class. N4 & C2				
75 x 38	N	N	N	700
75 x 50	N	650	700	800
100 x 38	600	750	850	950
100 x 50	750	850	1000	1100
Jack rafters/trusses with terracotta tile roof @ 600 mm max. spacing. Wind Class. N4 & C2				
75 x 38	N	N	N	650
75 x 50	N	550	700	700
100 x 38	450	800	850	900
100 x 50	850	900	900	950

Notes

1. N denotes Not Suitable
2. NA denotes size is Not Available
3. Maximum roof pitch = 35°
4. Maximum undersized 3mm

Table 9 - Stiffener Fixing Requirements - Seasoned timbers

Size	Grade							
	F5	F8	F11	MGP10	MGP12	MGP15	Hychord	F17
	Maximum overhang with no stiffener required to support guardrail post							
Jack rafters/trusses with sheet roof @ 900 mm maximum spacing. Wind Classification N4 & C2								
70 x 35	N	N	N	N	N	400	750	700
70 x 45	N	N	650	N	N	750	NA	800
90 x 35	N	N	800	N	700	900	950	900
90 x 45	N	750	900	N	800	1000	NA	1050
Jack rafters/trusses with sheet roof @ 1200 mm maximum spacing. Wind Classification N4 & C2								
70 x 35	N	N	N	N	N	350	650	600
70 x 45	N	N	550	N	N	650	NA	700
90 x 35	N	N	700	N	600	750	800	800
90 x 45	N	650	750	N	700	850	NA	900
Jack rafters/trusses with terracotta tile roof @ 600 mm maximum spacing. Wind Classification N4 & C2								
70 x 35	N	N	N	N	N	250	700	550
70 x 45	N	N	400	N	N	800	NA	800
90 x 35	N	N	850	N	650	1000	900	950
90 x 45	N	850	950	N	1000	1050	NA	1000

Notes

1. N denotes Not Suitable
2. NA denotes size is Not Available
3. Maximum roof pitch = 35°

TRUSS INSTALLATION

Trusses and jack rafters that support guardrail loads are to be installed in accordance with AS4440 and with additional fixing as specified in Figure 4.

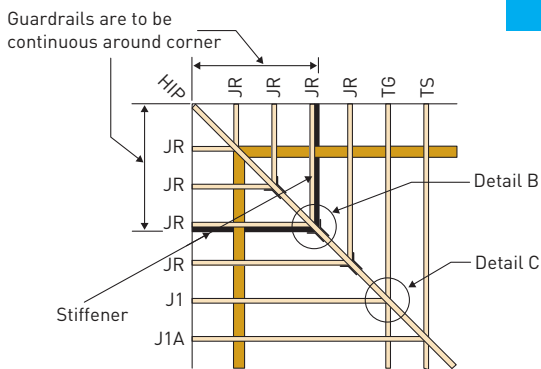

RT119

Detail C. Fixing of Jack Rafter to Hip Truss

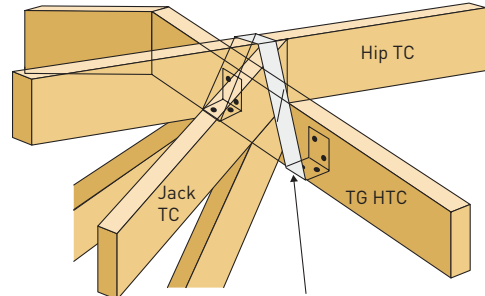

RT121

MiTek Structural Tie Down Strap (TD2230) with 4 No. 30 x 2.8 diameter reinforced head nails to each end of strap

Detail B. Fixing of Hip Truss to Truncated Girder Truss

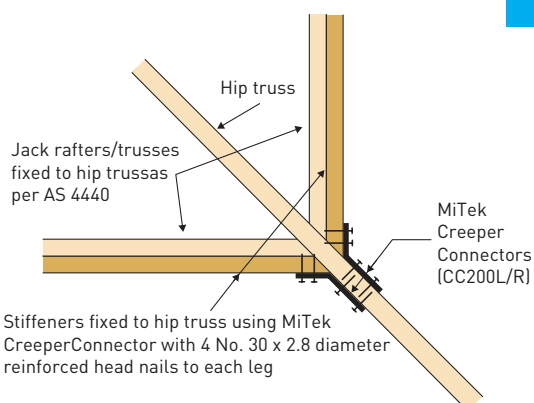

RT120

MITEK 20/20 USER GUIDE M2UG-0041

INDEX TO MITEK 20/20 FIXING LABELS

The following index provides a description of the various hold down and hanger fixing labels that appear in MiTek 20/20 output.

Notes: Refer to the particular product specification data sheet for its complete fixing instructions.

Index to MiTek 20/20 Fixing Labels			
Label	Product	Brief Description	Reference
3.15DIA -2	Framing nails, to size & number shown	Fix 2/3.15 dia. framing nails.	AS1684 & AS4440 standards
AS4440HDown	Framing nails, nominal fixing	Fix 2/65mm scew nails into the side of each member	AS4440 standards
BC200 Single Fold (Double Fold)	Boomerang Connector, to fold method shown	Fix Boomerang Connector with 2.8 dia. MiTek nails using Single Fold or Double Fold method around mitre cut. (Refer data sheet for folding instructions)	Boomerang Connector data sheet
BF	BlockFast	Fix BlockFast to concrete masonry with FAP32V5 hardened electro-galvanized nails in method shown: Heel – Fix at truss heel Wrap – Wrap and fix over web joints Vert – Fixed vertically to side of web Install a pair if "Dbl" as indicated.	BlockFast data sheet
BP80	BearingPlate	Fix BearingPlate with 3.75 dia. MiTek nails to top plate directly under girder.	BearingPlate data sheet
CC200	CreeperConnector, in straight, (L)eft or (R)ight hand version as shown	Join members together with 3/75mm framing nails before fixing CreeperConnector with 2.8 dia. MiTek nails. (Refer data sheet for folding instructions)	CreeperConnector data sheet
CC200R & CT600 Under	CreeperConnector + CycloneTie combination	Refer to individual product descriptions for their fixing requirements.	CreeperConnector & CycloneTie data sheet
CF1 Type A	Concrete FixingCleat	Fix Concrete FixingCleat into concrete masonry with MiTek screws. Type A - 6 MiTek screws into truss with 40mm sq. x 5mm washers (supplied) to M12 tie down. Install a pair if "Dbl" is indicated. Double cleat for up to double truss. Type B - 12 MiTek screws into truss with 50mm x 100mm x 5mm washer (by others) to M16 tie down. Install a pair if "Dbl" is indicated. Double truss only for double cleat.	Concrete FixingCleat data sheet
CPC40 2x1430 Sup/2x1430 Tr	Concealed Purlin Cleat	Fix CPC40 with 2 MiTek screws into support (Sup) and 2 MiTek screws into truss (Tr). Install a pair if "Dbl" is indicated.	Concealed Purlin Cleat data sheet
CPC80 4x1430 Sup/4x1430 Tr	Concealed Purlin Cleat	Fix CPC80 with 4 MiTek screws into support (Sup) and 4 MiTek screws into truss (Tr). Install a pair if "Dbl" is indicated.	Concealed Purlin Cleat data sheet
CT180L 8 Face CT180R 8 Face	CycloneTie (L)eft or (R)ight 180mm long with number of nails shown	Fix CycloneTie with 4 nails to support and 4 nails to supported member.	CycloneTie data sheet
CT400 (CT600, CT900) 8 Face	CycloneTie, in 400mm, 600mm or 900mm length with number of nails shown	Fix CycloneTie to support "Face" with 8/2.8 dia. MiTek nails, i.e. 4 nails in each leg. Wrap and fix legs under support if "Fixed Under" is indicated. Install a pair of CycloneTies if "Dbl" is indicated.	CycloneTie data sheet
CT600 W-Under & 2TGL	CycloneTie CT600 + TGL	Fix CycloneTie wrap under support plus number of Trip-L-Grip as indicated	CycloneTie datasheet
CT600SS 8 Face	CycloneTie, in stainless steel with number of nails shown	Fix stainless steel CycloneTie to support face with 8 stainless steel MiTek nails, i.e. 4 nails in each leg. Install a pair if "Dbl" is indicated.	Stainless Steel CycloneTie data sheet
CT1200 Type 12 Face	CycloneTie, in 1200mm length to method shown	Fix CycloneTie to support "Face" with 12/2.8 dia MiTek nail, i.e. 6 nails in each leg. Wrap and fix legs under support if "Fixed Under" is indicated. Install a pair of CycloneTies if "Dbl" is indicated. 4+4 in Stud – Rafter/Truss fixing to Stud with 4 MiTek nails in each leg.	CycloneTie data sheet
GB340 Bolt (or Screw)	FastFit MkIII Girder Bracket, to size shown	Fix MkIII Girder Bracket with M12 bolts (or MiTek screws). Girder is "Dbl" or "Trpl" ply where indicated.	Girder Brackets data sheet

Label	Product	Brief Description	Reference
GB340 Bolt & Screw	FastFit MkIII Girder Bracket, to size shown	Fix MkIII Girder Bracket with M12 bolts in wings and MiTek screws in shoe. Girder is "Dbl" or "Trpl" ply where indicated.	Girder Brackets data sheet
GB340 Screw & Bolt	FastFit MkIII Girder Bracket, to size shown	Fix MkIII Girder Bracket with MiTek screws in wings and M12 bolts in shoe. Girder is "Dbl" or "Trpl" ply where indicated.	Girder Brackets data sheet
GB340 Cyc	FastFit MkIII Cyclonic Girder Bracket, to size shown	Fix MkIII Cyclonic Girder Bracket with MiTek screws and M12 bolts. Girder is "Dbl" or "Trpl" ply where indicated.	Girder Brackets data sheet
GB340 + HGB35	FastFit MkIII Cyclonic Girder Bracket + Hip Girder Bracket	Fix MkIII Cyclonic Girder Bracket together Hip Girder Bracket with MiTek screws. Girder is "Dbl" or "Trpl" ply where indicated.	Girder Brackets data sheet
GB440 (GB475) Bolt (or Screw)	FastFit MkIV Girder Bracket, to size shown	Fix MkIV Girder Bracket with M12 bolts (or MiTek screws). Girder is "Dbl" or "Trpl" ply where indicated.	Girder Brackets data sheet
GB440 120BC	FastFit MkIV Girder Bracket	Fix MkIV Girder Bracket with MiTek screws for 120mm girder truss bottom chord. Girder is "Dbl" or "Trpl" ply where indicated.	Girder Brackets data sheet
GB440 + HGB35	FastFit MkIV Cyclonic Girder Bracket + Hip Girder Bracket	Fix MkIV Cyclonic Girder Bracket together Hip Girder Bracket with MiTek screws. Girder is "Dbl" or "Trpl" ply where indicated.	Girder Brackets data sheet
GBH Bolt Dbl Sup Trpl	HiLoad Girder Bracket	Fix HiLoad Girder Bracket with M16 bolts into double (Dbl) girder to (Sup) port triple (Trpl) truss. Install additional CT1200 if "Strap" is indicated.	Universal Girder Brackets data sheet
GBH Bolt CT1200	HiLoad Girder Bracket and CT1200 CycloneTie	Fix HiLoad Girder Bracket with M16 bolts and strap diagonal hip truss down with CT1200 CycloneTie.	Universal Girder Brackets data sheet
GBH Bolt Strap	HiLoad Girder Bracket and over-strap	Fix HiLoad Girder Bracket with M16 bolts and heavy duty over-strap to supported truss when "Strap" is shown. Refer to MiTek User Guide MIUG-0041 for details of over-strap.	Universal Girder Brackets data sheet & MIUG-0041 user guide
GBM Bolt	MidLoad Girder Bracket	Fix MidLoad Girder Bracket with M12 bolts. Girder is "Dbl" or "Trpl" ply where indicated. Strap down diagonal hip truss with CycloneTie if "CT1200" is shown.	Universal Girder Brackets data sheet
GBBL22 Bolt Strap	Boomerang Girder Bracket, in (L)eft or (R)ight hand version of angle shown and over-strap	Fix Boomerang Girder Bracket with M16 bolts and heavy duty over-strap to supported truss when "Strap" is shown. Refer to MiTek User Guide MIUG-0041 for details of over-strap.	Universal Girder Brackets data sheet & MIUG-0041 user guide
IBHF20050 4 Screws	FaceFix I-BeamHanger, in size shown and fixing indicated	Fix 50x200 FaceFix I-BeamHanger into supporting beam with 4 MiTek screws in each flange and into supported joist with 3.75 dia. nails through dimples.	I-BeamHangers data sheet
IBHT24090 6 Nails Top	TopFix I-BeamHanger	Fix 90x240 TopFix I-BeamHanger into top of supporting beam with 6 nails and into supported joist with 3.75 dia. nails through dimples.	I-BeamHangers data sheet
JH3590	JoistHanger, in size shown	Fix 35x90 JoistHanger with MiTek nails. (Refer to instructions for number of nails required)	JoistHanger data sheet
JH40120 +4x3.15 nails	JoistHanger, to size shown + framing nails	Fix components together with 4/3.15 dia. framing nails in addition to JoistHanger.	JoistHanger data sheet
JH70160 Screw	JoistHanger, in size shown	Fix 70x160 JoistHanger with MiTek screws. (Refer to instructions for number of screws required)	JoistHanger data sheet
JHAL (or JHAR) Typ 1	45 Degree JoistHanger, to (L)eft or (R)ight hand version shown	Fix 45 Degree JoistHanger with MiTek nails according to one of the following methods: Typ 1: Both legs wrapped over truss Typ 2: Both legs up side of web Typ 3: One leg over truss, one leg up side of web (Refer product specifications for nailing pattern)	45 Degree JoistHanger data sheet
JST 3 Nails	JoistStrap	Fix JoistStrap to each member with number of MiTek nails indicated.	JoistStrap data sheet

Label	Product	Brief Description	Reference
MIUG25 1A	Truss hold down in blockwork, to method indicated	Refer to MiTek User Guide MIUG-0025 for details of truss hold down in blockwork using method type 1A.	MIUG-0025 user guide
MIUG26 3B	Truss hold down to timber framing, to method indicated	Refer to MiTek User Guide MIUG-0026 for details of truss hold down to timber framing using method type 3B.	MIUG-0026 user guide
MIUG30 25kN	Special hold down bracket, to uplift capacity shown	Refer to supplier for details of 25kN capacity truss hold down bracket fixed to side of truss.	M2UG-0030 user guide
MIUG30U 40kN	Special hold down bracket, to uplift capacity shown	Refer to supplier for details of 40kN capacity truss hold down bracket fixed with strap over joint.	M2UG-0030 user guide
MIUG30V 50kN	Special hold down bracket, to uplift capacity shown	Refer to supplier for details of 50kN capacity truss hold down bracket fixed to vertical web of truss.	M2UG-0030 user guide
MIUG43 1A	Anchor rod hold down, to method indicated	Refer to supplier for details of truss hold down with cleat over truss held down by anchor rods on both sides using method type 1A.	MIUG-0043 user guide
SL170HD Sng	StudLok screw 170mm long	Fix one screw to each truss for truss hold down from the top of the truss heel into a timber support. Truss is "Sng" "Dbf" or "Trpl" ply where indicated.	StudLok datasheet
SL170HD Sng + CT180	StudLok screw 170mm long with CycloneTie CT180	Fix components together with CT180 in addition to StudLok SL170.	StudLok and CycloneTie data sheet
SPH140 6 Scrw / 6 Scrw	SplitHangers, to size and fixing shown	Fix a pair of 140mm deep SplitHangers with 6 MiTek Screws in each flange.	SplitHanger data sheet
SPH140SS 6 Scrw / 6Scr w	Stainless Steel SplitHangers, to size and fixing shown	Fix a pair of 140mm deep Stainless Steel SplitHangers with 6 MiTek Screws in each flange.	Stainless Steel SplitHanger data sheet
TBS (TBS+)	Special hanger (or special hold down)	Refer to supplier for details of special hanger or hold down fixing.	Supplier to provide
TGL (or TGR) A	Trip-L-Grip, (L)eft or (R)ight hand version	Fix Trip-L-Grip in orientation A (Refer product sheet). Install a pair if "Dbf" is indicated.	Trip-L-Grip data sheet
TGLSS (or TGRSS) A	Stainless Steel Trip-L-Grip, (L)eft or (R)ight hand version	Fix SS Trip-L-Grip in orientation A (Refer product sheet). Install a pair if "Dbf" is indicated.	Stainless Steel Trip-L-Grip data sheet
TGM E	MultiGrip	Fix MultiGrip in orientation E (Refer product sheet). Install a pair if "Dbf" is indicated.	MultiGrip data sheet
TGU A	Universal Trip-L-Grip	Fix Universal Trip-L-Grip in orientation A (Refer product sheet). Install a pair if "Dbf" is indicated.	Universal Trip-L-Grip data sheet
TGUSS A	Universal Trip-L-Grip, in stainless steel to orientation shown	Fix stainless steel Universal Trip-L-Grip in orientation A (Refer product sheet). Install a pair if "Dbf" is indicated.	Stainless Steel Universal Trip-L-Grip data sheet
TL150HD Sng	TrussLok screw	Truss hold down through top plate. Truss is "Sng" "Dbf" or "Trpl" ply where indicated.	TrussLok data sheet
TRG	TrussGrip	Fix TrussGrip to side of truss and support. Install a pair if Dbf is indicated.	TrussGrip data sheet
UL7550 Floor	UniLedger	Fix UniLedger to supporting beam with MiTek screws, and with 10g screw to supported member. Also fix top of members together with framing nails.	UniLedger data sheet
UL7550 + 2xCT1200	UniLedger + CycloneTie, to number shown	Fix UniLedger to girder truss with MiTek screws, and strap down each supported truss to girder truss with CT1200 CycloneTie.	UniLedger data sheet

TRUSS INSTALLATION CHECKLIST

When installing your roof trusses use the following checklist to ensure a quality job and to avoid overlooking any important aspects.

SUPPORTING STRUCTURE

- Check that all top plates that support trusses are level and straight. (Any misalignment of supporting structure will be reflected in the straightness of the roof.)
- Check that the distance between supporting walls match the spans of the trusses.
- Are the tops of internal non-load bearing walls set down below that of external load bearing walls?
- Are lintels in load bearing walls suitable for truss loading?
- Is supporting structure fully braced, plumb and stable?

ROOF TRUSSES

- Have trusses been stored and lifted in accordance with these instructions?
- Are trusses free of any modifications, cut members or broken members?
- Does the truss design criteria on the documentation conform to the job specification for roof cladding and special loads, eg roof mounted hot water tanks, air conditioners, etc?
- Are trusses correctly positioned according to truss layout plan?
- Are trusses accurately spaced?
- Have cantilever or internally supported trusses been orientated correctly i.e. are "Support Here" labels located above bearing walls?
- Are trusses installed within installation tolerances:
 - (a) Plumb - All sections of truss less than 50mm or height/50 out of vertical?
 - (b) Bow - All chord bows less than 50mm or chord length/200?
- Are all multiple ply trusses nailed/screwed/bolted together?
- Are all waling plates fixed to truss as per design?
- Is gable end framing as per design?
- Do all trusses in corrosive environments have stainless steel plates and/or other suitable protection?

TEMPORARY BRACING

- Are top chord temporary ties no greater than 3000mm spacing?
- Are bottom chord temporary ties no greater the 4000mm spacing?

PERMANENT BRACING

Top Chord Bracing

- Is the SpeedBrace configuration correct according to "Fixing & Bracing Guidelines"?
- Is the SpeedBrace apex fixing correct according to "Fixing & Bracing Guidelines"?

- Is the SpeedBrace fixing to each truss top chord correct according to "Fixing & Bracing Guidelines"?
- Is the SpeedBrace to top plate fixing correct according to "Fixing & Bracing Guidelines"?
- Is the SpeedBrace splice detail correct according to "Fixing & Bracing Guidelines"?
- Has all cantilever and web bracing been installed as per design?
- Have all web ties been installed and braced back to a rigid part of the building with cross braces?
- Are roof battens of correct size and grade?
- Are roof battens fixed to each truss including to each ply of double & triple girders using the correct size nails?
- Are roof battens spliced correctly:
 - (a) no more than 1 in 3 on any truss?
 - (b) no 2 splices adjacent on any truss and none in unbraced zones of gable roof ends?
- Are intermediate top chord ties fixed between saddle trusses (if applicable)?

Bottom Chord Bracing

- For suspended ceilings or where furring channels are "clipped" to bottom chords: have bottom chord ties and diagonal bracing been installed in accordance with AS 4440?

TRUSS CONNECTION DETAILS

- Have trusses been fixed to top plates correctly at:
 - (a) load bearing wall i.e. Trip-L-Grip?
 - (b) internal non-brace wall i.e. Internal Wall Bracket?
 - (c) internal braced wall i.e. blocking pieces fixed in accordance with AS 4440?
- Have hip end components been fixed correctly at:
 - (a) jack truss to hip truss - small stations i.e. nailed?
 - (b) jack truss to hip truss - large station i.e. Creeper Connector?
 - (c) hip truss & jack trusses to truncated girder and to truncated standard truss as per AS 4440?
 - (d) structural fascia and/or strutted overhangs?
- Are saddle trusses fixed in accordance with AS 4440?
- Are standard truss to girder truss fixing type according to approved plans and are all nails/bolts installed and tight?
- Has all strengthening been completed for guard rail systems (if applicable)?

PRODUCT CERTIFICATION

All MiTek products specified in this guideline are engineered building products that have been designed, developed and tested in the corporate engineering laboratory of MiTek Australia to comply with the requirements of the Building Code of Australia. The design values, applications and specifications of these products are certified by qualified chartered engineers and they are published in individual product brochures freely available on the MiTek website. Nail guns should not be used to substitute reinforced head nails in connector fixings, except in specific instances where it is approved and instructions are provided. Further information, support and guidance on any of these products may be obtained by contacting one of our offices listed below.

This manual is available
anytime, anywhere! - Download



EASYCAT
FREE APP



NSW
+61 2 8525 8000

QLD
+61 7 3861 2100

SA
+61 8 8234 1326

VIC
+61 3 8795 888

WA
+61 8 6279 8925

MITEK.COM.AU